

## GENERAL DESCRIPTION

**Model T** flow meters incorporate the principles of traditional variable area flow technology.

**These rugged PTFE-Glass flow meters offer solutions to low to medium flow range measurements of highly corrosive or ultra-pure liquids and gases.**

Wetted inert components are surrounded by structurally rigid anodized aluminum. The resultant design represents a unique combination of a rugged mechanically rigid frame and chemically inert wetted parts.

For additional protection of personnel each meter is supplied with a thick protective magnifying safety shield.

\*Glass and Sapphire floats are recommended.

### design features

- ✓ Constructed of inert materials: Borosilicate Glass, PTFE and PEEK.
- ✓ Chemically inert wetted parts within mechanically rigid frame.
- ✓ Rib-guided or fluted metering tubes facilitate stable, accurate readings.
- ✓ Magnifier lens in front shield to enhance reading resolution.
- ✓ OPTIGRAD™ scales minimize parallax and eye fatigue.
- ✓ Simple means of panel mounting.
- ✓ Interchangeability of flow tubes and floats.
- ✓ Conveniently overlapping flow ranges available in both standard millimeter and “direct reading” scales.



# T

## PTFE-SINGLE GLASS FLOW METERS

### LEAK INTEGRITY

Flow meters are individually tested on a Mass Spectrometer Leak Detector and certified to a leak integrity rating of  $1 \times 10^{-7}$  sccs Helium or better.

### BUILT-IN VALVES

Meters are available with built-in needle valves (CVT™), high precision metering valves (MVT™) with “non-rising stems”, or with no valves. The higher cost of MVT™ valves is justified whenever high sensitivity control and resolution are desirable particularly in conjunction with metering tubes of very low flow rates.

When meters with valves are ordered the valve cartridges are installed at the inlet. For vacuum service it is recommended that meters are ordered with valves at the outlet.

Assorted flow tubes may be used in conjunction with a single mounting frame, an apparent benefit in many laboratory applications.

### SPECIFICATIONS

<b>STANDARD ACCURACY</b>	±2% FS mm scales except 042 and 032 flow tubes. ±5% FS direct reading scales 042 and 032 flow tubes.
<b>REPEATABILITY</b>	± 0.25%.
<b>USEFUL FLOW RANGES</b>	10:1 minimum with one float.
<b>MAXIMUM OPERATING PRESSURE</b>	100 psig/6.7 bars.
<b>MAXIMUM OPERATING TEMPERATURE</b>	150 °F/ 65 °C.
<b>LEAK INTEGRITY</b>	Individually pressure and leak tested and certified to a rating of $1 \times 10^{-7}$ sccs Helium.

### \*\*MATERIALS OF CONSTRUCTION

<b>FLOW TUBES</b>	Heavy walled borosilicate glass. (Sapphire or glass floats recommended).
<b>FITTINGS IN CONTACT WITH FLUIDS</b>	Virgin PTFE and PEEK.
<b>SIDE PLATES</b>	Aluminum, black anodized.
<b>FRONT SHIELD AND BACK PLATE</b>	1/8" thick clear polycarbonate and white acrylics.
<b>O-RINGS</b>	PTFE.
<b>CONNECTIONS</b>	1/8" NPT female inlet and outlet connections.
<b>OPTIONAL</b>	glass hose nipples or compression fittings.

\*\*The selection of materials of construction, is the responsibility of the customer. The company accepts no liability.

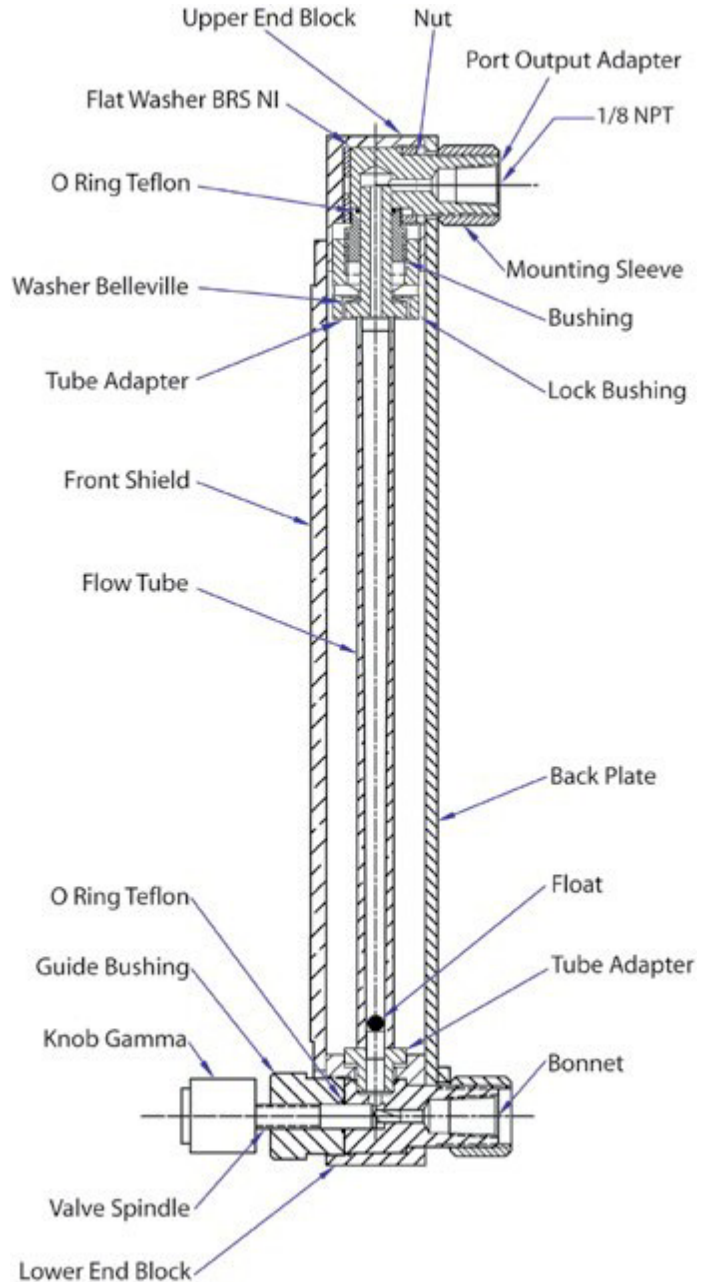

Panel mounting is convertible to bench mounting through the use of an optional acrylic tripod base with spirit leveler (catalog No. TP1)

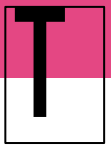

Four Tube PTFE meter shown with CVT™ valves

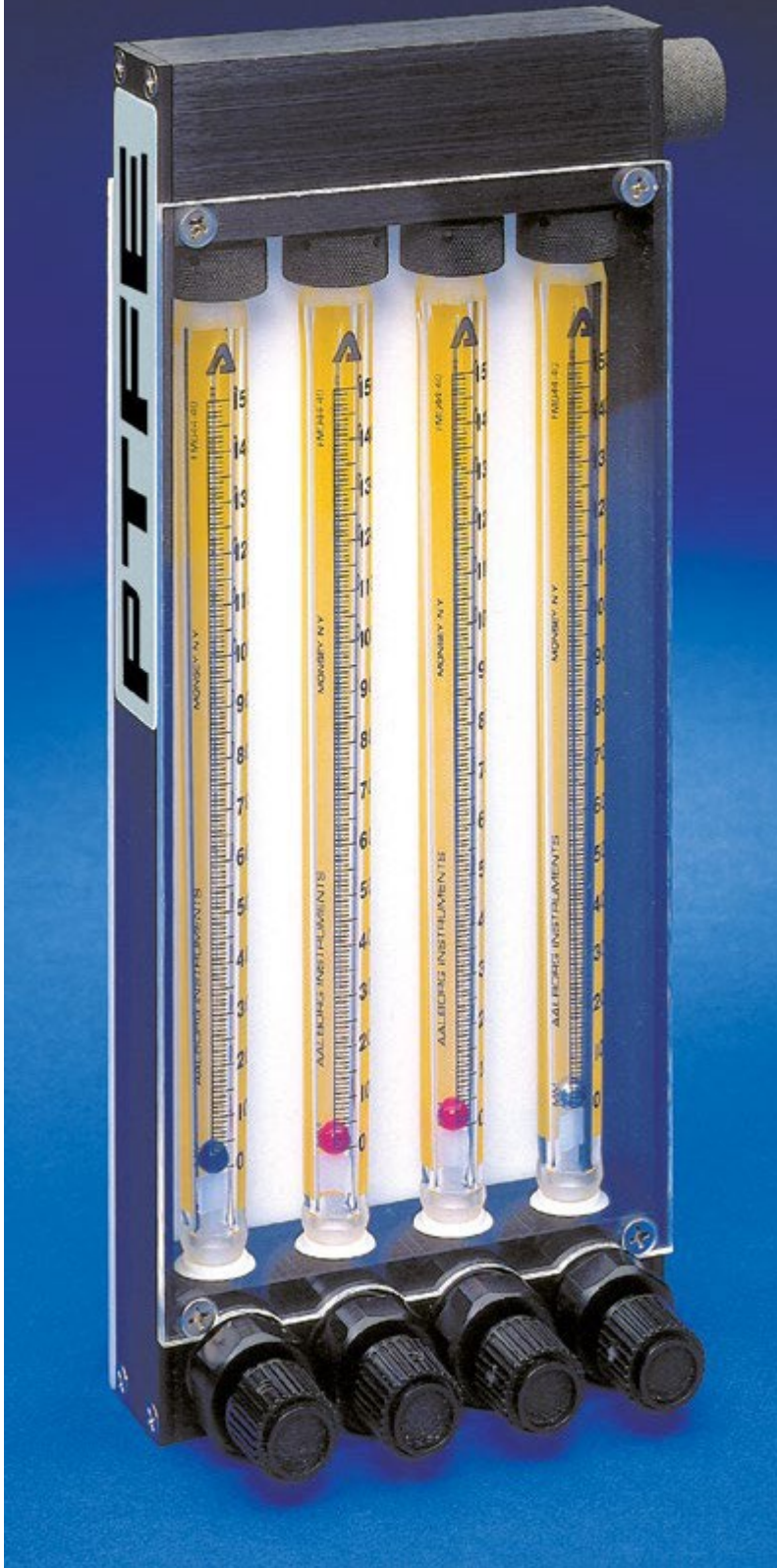

Model Tx Multiple Tube PTFE-Glass Flow meters combine the convenience of multiple tube meters with the unique design features of single tube PTFE-Glass flow meters. These meters are available with the same interchangeable 65mm or 150mm glass flow tubes used in single tube designs and they are available with or without built-in PTFE needle valves.

Wetted inert components are surrounded by structurally rigid anodized aluminum. The resultant design represents a unique combination of a rugged mechanically rigid frame and chemically inert wetted parts.

**They are ideal for applications where several streams of corrosive gases or liquids are to be metered in individual channels or as a controlled mixer in manifolded models.**

## design features

- ✓ Constructed of inert materials: Borosilicate Glass, PTFE and PEEK.
- ✓ Chemical inert wetted parts within mechanically rigid frame.
- ✓ Rib-guided or fluted metering tubes facilitate: stable, accurate readings.
- ✓ OPTIGRAD™ scales minimize parallax and eye fatigue.
- ✓ Simple means of panel mounting.
- ✓ Interchangeability of flow tubes and floats.
- ✓ Conveniently overlapping flow ranges available in both standard millimeter and direct reading scales.

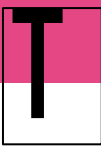

# PTFE-SINGLE GLASS FLOW METERS

## BUILT-IN VALVES

Meters are available with built-in needle valves (CVT™), high precision metering valves (MVT™) with non-rising stems, or with no valves. The higher cost of MVT™ valves is justified whenever high sensitivity control and resolution are desirable particularly in conjunction with metering tubes of very low flow rates.

**For vacuum service it is recommended that meters are ordered with valves at the outlet.**

## DIMENSIONS

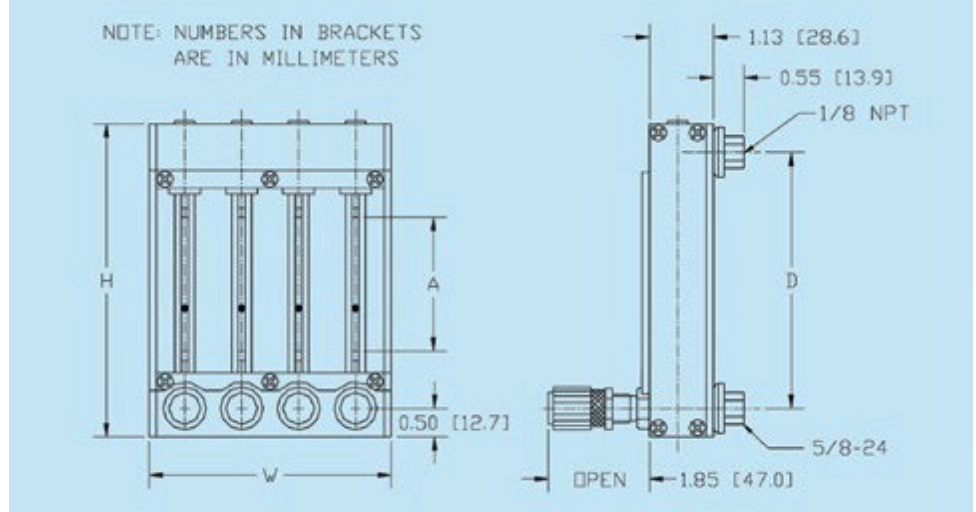

## LEAK INTEGRITY

Flow meters are individually tested on a Mass Spectrometer Leak Detector and certified to a leak integrity rating of  $1 \times 10^{-7}$  sccs Helium or better.

## SPECIFICATIONS

<b>STANDARD ACCURACY</b>	$\pm 2\%$ FS mm scales except 042 and 032 flow tubes. $\pm 5\%$ FS direct reading scales and 042 and 032 flow tubes.
<b>REPEATABILITY</b>	$\pm 0.25\%$ .
<b>USEFUL FLOW RANGES</b>	10:1 minimum with one float.
<b>MAXIMUM OPERATING PRESSURE</b>	100 psig/6.7 bars.
<b>MAXIMUM OPERATING TEMPERATURE</b>	150 °F/ 65 °C.
<b>LEAK INTEGRITY</b>	Individually pressure and leak tested and certified to a rating of $1 \times 10^{-7}$ sccs Helium.

## \*\*MATERIALS OF CONSTRUCTION

<b>FLOW TUBES</b>	Heavy walled borosilicate glass. (Sapphire or glass floats recommended).
<b>FITTINGS IN CONTACT WITH FLUIDS</b>	Virgin PTFE and PEEK.
<b>SIDE PLATES</b>	Aluminum, black anodized.
<b>FRONT SHIELD AND BACK PLATE</b>	1/8" thick clear polycarbonate and white acrylics.
<b>O-RINGS</b>	PTFE.
<b>CONNECTIONS</b>	1/8" NPT female inlet and outlet connections.
<b>OPTIONAL</b>	glass hose nipples or compression fittings.

\*\*The selection of materials of construction, is the responsibility of the customer. The company accepts no liability.

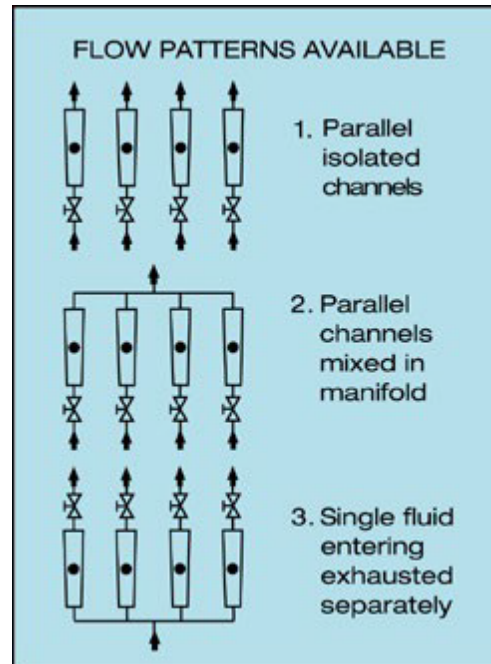

**When meters with valves are ordered the valve cartridges are installed at the inlet.**

## DIMENSIONS FOR T STYLE METERS

SCALE LENGTH (A)	ALL METERS		WIDTH (W)			
	HEIGHT (H)	CENTER TO CENTER (D)	TUBE 1	TUBE 2	TUBE 3	TUBE 4
65mm	6.156	5.156	1.250	2.250	3.250	4.250
150mm	10.46	9.469	1.250	2.250	3.250	4.250