

Design Features

- Rigid metallic construction.
- Maximum pressure of 1000 psig (70 bars).
- Leak integrity 1×10^{-9} of helium.
- NIST traceable certification.
- Built-in tiltable LCD readout.
- 0-5 Vdc and 4-20 mA signals.
- Circuit protection.
- Can be used as a portable device.
- Engineering units or 0 to 100% displays.
- TIO Totalizer option.

Typical Aluminum GFM Mass Flow Meter



Principles of Operation

Metered gases are divided into two laminar flow paths, one through the primary flow conduit, and the other through a capillary sensor tube. Both flow conduits are designed to ensure laminar flows and therefore the ratio of their flow rates is constant.

Two precision temperature sensing windings on the sensor tube are heated, and when flow takes place, gas carries heat from the upstream to the downstream windings. The resultant temperature differential is proportional to the change in resistance of the sensor windings.

A Wheatstone bridge design is used to monitor the temperature dependent resistance gradient on the sensor windings which is linearly proportional to the instantaneous rate of flow.

Output signals of 0 to 5Vdc and 4 to 20mA are generated indicating mass molecular based flow rates of the metered gas.

Flow rates are unaffected by temperature and pressure variations within stated limitations.

General Description

Compact, self-contained GFM mass flow meters are designed to read flow rates of gases. The rugged design coupled with instrumentation grade accuracy provides versatile and economical means of flow measurement.

Aluminum or stainless steel models with readout options of either engineering units (standard) or 0 to 100 percent displays are available.

The mechanical layout of the design includes an LCD readout built into the top of the transducer. This readout module is tiltable over 90 degrees to provide optimal reading comfort. It is connected to the transducer by a standard modular plug, and is also readily removable for remote reading installations.

GFM 57, 67 and 77
High Flow Mass Flow Meters



TABLE 1 - SPECIFICATIONS FOR GFM

ACCURACY:	GFM 17, 37 and 47: ±1.0% of full scale. GFM 57, 67 and 77: ±1.5% of full scale. OPTIONAL ENHANCED ACCURACY: ±1.0% of full scale.
CALIBRATIONS:	Performed at standard conditions [14.7 psia (101.4 kPa) and 70 °F (21.1 °C)] unless otherwise requested.
REPEATABILITY:	±0.25% of full scale.
RESPONSE TIME:	Generally 2 seconds to within ±2% of actual flow rate over 25 to 100% of full scale.
TEMPERATURE COEFFICIENT:	0.15% of full scale / °C.
PRESSURE COEFFICIENT:	0.01% of full scale / psi (0.07 bar).
MAXIMUM PRESSURE DROP:	See Table 3.
GAS AND AMBIENT TEMP.:	Gas: 32 °F to 122 °F (0 °C to 50 °C). Ambient: 14 °F to 122 °F (-10 °C to 50 °C) - Dry gases only.
OUTPUT SIGNALS:	Linear 0-5 Vdc. 1000 ohms min. load impedance and 4-20 mA 0-500 Ohms loop resistance.
TRANSDUCER INPUT POWER:	Universal +12 to +26 Vdc, 200 mA maximum.
TIME CONSTANT:	800 ms.
GAS PRESSURE:	1000 psig (70 bars) maximum GFM 17, 37, 47. 20 psig (1.4 bars) optimum. 500 psig (34.5 bars) GFM 57, 67, 77. 20 psig (1.4 bars) optimum.
** MATERIALS IN FLUID CONTACT:	a. Aluminum models GFM Series: anodized aluminum, 316 stainless steel, brass and Viton® O-rings. b. Stainless steel models GFM17S, 37S,47S, 57S, 67S and 77S: 316 stainless steel and Viton® O-rings. Optional O-rings: Buna®, EPR and Kalrez®.
ATTITUDE SENSITIVITY:	No greater than +15 degree rotation from horizontal to vertical; standard calibration is in horizontal position.
CONNECTIONS:	GFM 17: 1/4" compression fittings. Optional: 6mm, 3/8" and 1/8" compression fittings or 1/4" VCR®. GFM 37: 1/4" compression fittings. Optional: 6mm and 3/8" compression fittings or 1/4" VCR®. GFM 47: 3/8" compression fittings. GFM 57: 3/8" compression fittings. GFM 67: 1/2" compression fittings. GFM 77: 3/4" FNPT fittings or 3/4" compression fittings.
LEAK INTEGRITY:	1 x 10 ⁻⁹ s mL/sec of helium maximum to the outside environment.
CE COMPLIANT:	EN 55011 class 1, class B; EN50082-1.

** The selection of materials of construction, is the responsibility of the customer. The company accepts no liability.

Transducers without LCD readout are offered for OEM applications.

GFM mass flow meters are available with flow ranges from 10 mL/min to 1000 L/min N₂. Gases are connected by means of 1/4" ,3/8" ,1/2" compression fittings and 3/4" FNPT fittings. Optional fittings are available. These meters may be used as bench top units or mounted by means of screws in the base.

Transducer power supply ports are fuse and polarity protected.

TABLE 2 - FLOW RANGES FOR GFM

GFM 17 LOW FLOW MASS FLOW METERS	
CODE	mL/min [N ₂]
01	0 to 10
02	0 to 20
03	0 to 50
04	0 to 100
05	0 to 200
06	0 to 500
CODE	L/min [N ₂]
07	0 to 1
08	0 to 2
09	0 to 5
10	0 to 10
GFM 37 MEDIUM FLOW MASS FLOW METERS	
11	0 to 15
30	0 to 20
31	0 to 30
32	0 to 40
33	0 to 50
GFM 47 HIGH FLOW MASS FLOW METERS	
40	0 to 60
41	0 to 80
42	0 to 100
GFM 57 HIGH FLOW MASS FLOW METERS	
50	0 to 200
GFM 67 HIGH FLOW MASS FLOW METERS	
60	0 to 500
GFM 77 HIGH FLOW MASS FLOW METERS	
70	0 to 1000

Leak Integrity

1 x 10⁻⁹ smL/sec of helium max to outside environment.

TABLE 3 - MAXIMUM PRESSURE DROP FOR GFM

MODEL	FLOW RATE [N ₂] [liters/min]	MAXIMUM PRESSURE DROP		
		[mm H ₂ O]	[psid]	[mbar]
GFM 17	up to 10	25	0.04	2.5
	20	300	0.44	30
	30	800	1.18	81
GFM 37	40	1480	2.18	150
	50	2200	3.23	223
	60	3100	4.56	314
	80	4422	6.5	448
GFM 47	100	5500	8.08	557
	200	2720	4.0	280
GFM 57	500	3400	5.0	340
GFM 77	1000	6120	9.0	620

TABLE 4 - ACCESSORIES FOR GFM

POWER SUPPLY - BATTERY PACK - CABLES	
PS-GFM-110NA-2	Power Supply, 110 V / 12 Vdc /North America
PS-GFM-110NA-4	Power Supply, 110 V / 24 Vdc /North America
PS-GFM-230EU-2	Power Supply, 220 V / 12 Vdc /Europe
PS-GFM-230EU-4	Power Supply, 220 V / 24Vdc /Europe
PS-GFM-240UK-2	Power Supply 240 V / 12 Vdc /United Kingdom
PS-GFM-240UK-4	Power Supply 240 V / 24 Vdc /United Kingdom
PS-GFM-240AU-2	Power Supply 240 V / 12 Vdc /Australia
PS-GFM-240AU-4	Power Supply 240 V / 24 Vdc /Australia
BP110	Battery Pack, 110 V (includes case)
BP220	Battery Pack, 220 V (includes case)
CBL-D4	Cable with 9-pin D-connector, (4 - 20 mA)
CBL-D5	Cable with 9-pin D-connector, (0 to 5 Vdc)
17/3RC	17/3RC Remote cable, 3 ft long
17/R	17/R Remote LCD readout with 3 ft long cable
TIO-LAA2	Totalizer I/O Monitor, RS-232 Digital Interface
TIO-LAA5	Totalizer I/O Monitor, RS-485 Digital Interface
KIT-TM-DD	GFM Flow Meter Mounting Kit with Two 9 Pin D-Connectors

GFM 17, 37 and 47 Mass Flow Meters

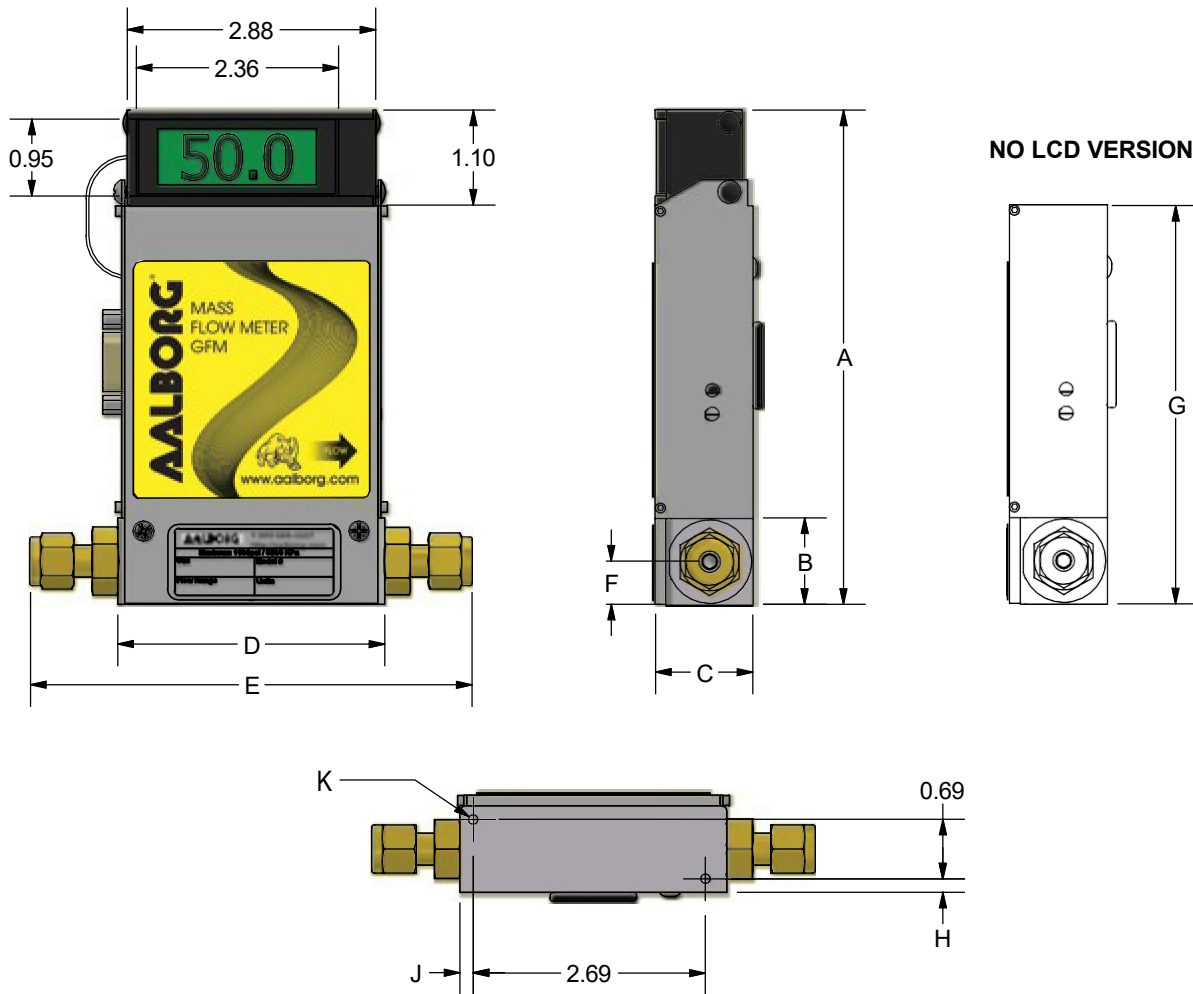

NOTE: Aalborg® reserves the right to change designs and dimensions at its sole discretion at any time without notice. For certified dimensions please contact Aalborg®.

TABLE 5 - DIMENSIONS FOR GFM 17, 37 AND 47 MODELS

MODEL	CONNECTION COMPRESSION FITTING	DIMENSION INCH (MM)										
		LCD VERSION						NO LCD	MOUNTING HOLE			
		A	B	C	D	E	F		H	J	K	
GFM 17	1/4" Tube O Diameter	5.72 (145.3)	1.00 (25.4)	1.13 (28.6)	3.09 (78.6)	5.10 (129.6)	0.5 (12.7)	4.61 (117.1)	0.16 (4.0)	0.16 (4.0)	6-32 x 0.13	
GFM 37	1/4" Tube O Diameter	6.10 (154.9)	1.38 (34.9)	1.25 (31.8)	4.13 (104.8)	6.13 (155.8)	0.63 (15.9)	4.99 (126.7)	0.28 (7.1)	1.08 (27.3)	6-32 x 0.10	
GFM 47	3/8" Tube O Diameter	6.10 (154.9)	1.38 (34.9)	1.25 (31.8)	4.13 (104.8)	6.25 (158.7)	0.63 (15.9)	4.99 (126.7)	0.28 (7.1)	1.08 (27.3)	6-32 x 0.10	

For Specific Flow Ranges Contact Aalborg Customer Service Department.

GFM 57, 67 and 77 Mass Flow Meters

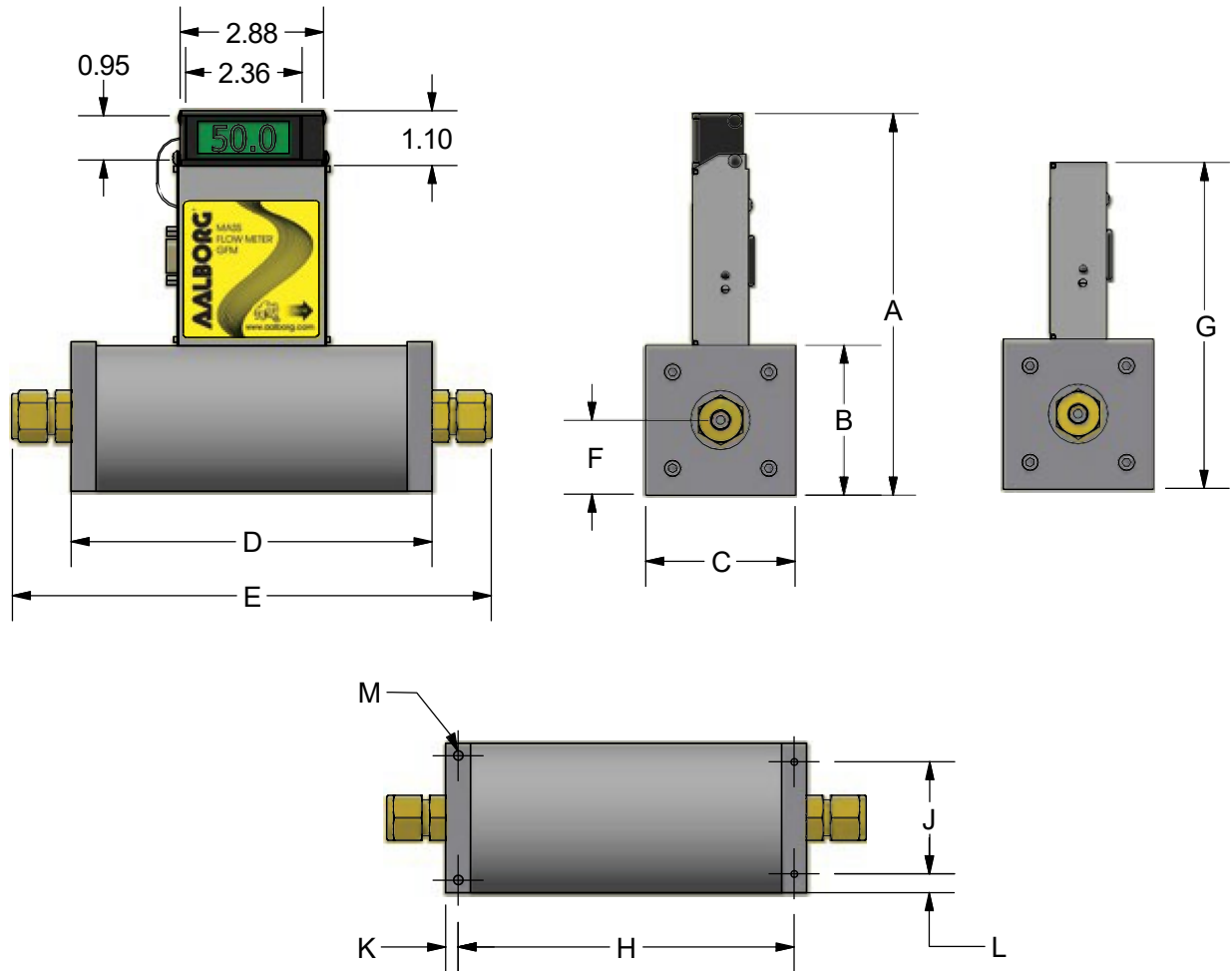

NOTE: Aalborg® reserves the right to change designs and dimensions at its sole discretion at any time without notice. For certified dimensions please contact Aalborg®.

TABLE 6 - DIMENSIONS FOR GFM 57, 67 AND 77 MODELS

MODEL	CONNECTION COMPRESSION FITTING (except model GFM 77)	DIMENSION (INCH)											
		LCD VERSION						NO LCD	MOUNTING HOLE				
		A	B	C	D	E	F	G	H	J	K	L	M
GFM 57	3/8" Tube O Diameter	6.73 (170.8)	2.00 (80.8)	1.75 (44.5)	6.69 (169.8)	8.81 (223.7)	0.88 (22.2)	5.62 (142.6)	4.69 (119.0)	1.39 (35.3)	1.00 (25.4)	0.18 (4.6)	10-24 x 0.25
GFM 67	1/2" Tube O Diameter	7.64 (194.0)	3.00 (76.2)	3.00 (76.2)	7.25 (184.2)	9.65 (245.1)	1.5 (38.1)	6.53 (165.8)	6.75 (171.5)	2.25 (57.2)	0.25 (6.4)	0.38 (9.5)	1/4-20 x 0.35
GFM 77	3/4" NPT Female	8.66 (220.0)	4.00 (101.6)	4.00 (101.6)	7.30 (185.4)	-	2.00 (50.8)	7.55 (191.8)	6.80 (172.7)	3.00 (76.2)	0.25 (6.4)	0.50 (12.7)	1/4-20 x 0.35

For Specific Flow Ranges Contact Aalborg Customer Service Department.