

DPC04, DPC07, DPC14, DPC17, DPC37 and DPC47



## DPC57, DPC67 and DPC77



## Design Features

- Simultaneously displays Mass Flow, Volumetric Flow, Pressure and Temperature.
- Multi-Gas functionality: support for 90 different gases and gas mixes.
- "User Defined Mixture" functionality allows to create and store up to 20 custom gas mixes with up to 5 different gases each.
- Quick (100-150 ms) response time.<sup>1</sup>
- Standard accuracy  $\pm (0.5\% \text{ RD} + 0.2\% \text{ FS})$ .
- 200 to 1 turn-down ratio.
- Two programmable mass flow rate totalizers.
- High, Low or In Range Alarms with preset action delay for Mass Flow, Temperature and Pressure.
- User programmable mass flow rate Pulse Output (via SSR).
- Extensive Self Diagnostics with status LED or OLED indication.
- All 3 user selectable analog input and output interfaces are standard: 0-5Vdc, 0-10Vdc, 4-20mA.
- Two user selectable digital communication interfaces (RS-232 and RS-485) are standard.
- Optional Modbus RTU network interface with isolated RS485 transceiver.
- User programmable solid state relay with latch option.
- Universal 12-26 Vdc power supply input (for DPC07/17/37/47). For DPC57/67/77 24-26Vdc.
- Local high contrast OLED (optional) graphic display with joystick control.
- Free, easy-to-use configuration and calibration software (RS-232/RS-485).
- Programmable set point table with ramping up/down capability up to 16 steps.

## General Description

Aalborg Instruments' DPC series precision digital mass flow controller provides accurate and stable control of mass flow rates, of process gases. With simultaneous displays of Mass Flow, Volumetric Flow, Pressure and Temperature parameters it can be used in a variety of industries: scientific and analytical applications, bioreactors and surface depositions, gas sampling, manufacturing and metrology activities.

DPC flow controllers support various functions including: user selectable local, analog, digital or program set point control, two programmable flow totalizers, low, high or range flow, temperature and pressure alarms, automatic zero adjustment (activated via local or communication interface), programmable SSR relay, programmable 0-5 Vdc, 0-10 Vdc or 4-20 mA analog inputs and outputs, user-programmable pulse output (via SSR), and extensive self-diagnostics functionalities.

DPC differential pressure mass flow controllers feature totalizers with batch processing mode (0.5% RD + 0.2%FS) standard accuracy, 200:1 turn-down ratio and less than 150 ms response time.

Significant savings are apparent, comparing to the cost of a single DPC embodying these features, with that of acquiring and installing multiple, application-specific devices.

## Principles of Operation

Operation of DPC flow controllers is based on the measurement of the differential pressure across specially designed restrictor flow elements. The restrictor flow element is designed to establish laminar flow across the entire range of the instrument's operation from 0 to 133% of full scale range.

A high accuracy and high resolution **differential** pressure sensor is utilized to measure pressure drop across a laminar flow channel, which is linearly proportional to volumetric flow rate. To convert volumetric flow into mass flow, high accuracy and high resolution **absolute** pressure and temperature sensors are utilized. Based on data from the sensors and gas properties from the built-in data base of the instrument, the micro-controller calculates volumetric and mass flow, which along with pressure and temperature parameters are available on the instrument display or via digital interfaces. In addition, the mass flow reading is accessible via the instrument analog interface which can be set by user to 0-5, 0-10 Vdc or 4-20mA mode.

1. For DPC with full scale 20 sml/min and lower the response time may be slightly longer.
2. Digital Signal provide access to Mass Flow, Volumetric Flow, Pressure, Temperature, Totalizers, Alarms.

TABLE 27 - DPC FLOW RANGES

MODEL NO.	FULL SCALE MASS FLOW RATE	PRESSURE DROP AT FULL SCALE FLOW (PSID)	PROCESS CONNECTION
<b>DPC04</b>	0.5 sml/min to 20 smL/min	0.08	10-32 Female Thread
<b>DPC07</b>	0.5 to 50 sml/min	1.0	10-32 Female Thread
<b>DPC14</b>	21 smL/min to 2 sL/min	0.19	1/8" NPT Female
<b>DPC17</b>	51 sml/min to 20 sL/min	1.0 - 20.0	1/8" NPT Female
<b>DPC37</b>	21 sL/min to 50 sL/min	5.0 - 8.5	1/4" NPT Female
<b>DPC47</b>	51 sL/min to 100 sL/min	10.0 - 20.0	1/4" NPT Female
<b>DPC57</b>	250 sL/min	2.5	1/2" NPT Female
<b>DPC67</b>	500 sL/min	6.9	3/4" NPT Female
<b>DPC77</b>	1000 sL/min	15.0	3/4" NPT Female

**TABLE 28 - DPC ACCESSORY'S**

<b>FITTINGS</b>		
<b>MODEL NO.</b>	<b>FITTING CODE</b>	<b>DESCRIPTION</b>
DPC04 / 07	F1C5	10-32 Thread, 1/8" Tubing, Compression, 316 ss.
DPC04 / 07	F2C5	10-32 Thread, 1/8" Tubing, Compression, Nickel Plated Brass.
DPC14 / 17	F2C2	1/8" NPT Thread, 1/8" tubing, Compression, 316 ss.
DPC14 / 17	F2C4	1/8" NPT Thread, 1/4" tubing, Compression, 316 ss.
DPC37	F4C4	1/4" NPT Thread, 1/4" tubing, Compression, 316 ss.
DPC47	F4C6	1/4" NPT Thread, 3/8" tubing, Compression, 316 ss.
DPC57	F8C6	1/2" NPT Thread, 3/8" tubing, Compression, 300 series ss.
DPC57	F8C8	1/2" NPT Thread, 1/2" tubing, Compression, 300 series ss.
DPC67/77	1210-1-12-316	3/4" NPT Thread, 3/4" tubing, Compression, 300 series ss.
<b>POWER SUPPLIES</b>		
PS-GFM-110NA-2	Power Supply, 110 V / 12 Vdc / North America.	
PS-GFM-110NA-4	Power Supply, 110 V / 24 Vdc / North America.	
PS-GFM-230EU-2	Power Supply, 220 V / 12 Vdc / Europe.	
PS-GFM-230EU-4	Power Supply, 220 V / 24Vdc / Europe.	
PS-GFM-240UK-2	Power Supply, 240 V / 12 Vdc / United Kingdom.	
<b>CABLES</b>		
CBL-A232	Communication Cable for DPC with RS-232 Interface 1.5 FT 3.5 mm stereo audio con. with 3-wire to 9 pins female D-connector (included with each DPC).	
CBL-A485	Communication Cable for DPC with RS-485 Interface 3 FT 3.5mm stereo audio con. with 3-wire to stripped ends.	
CBL-8MINIDIN-3	Shielded cable 8 pins MinDin with stripped ends 3 feet long.	
CBL-8MINIDIN-12	Shielded cable 8 pins MinDin with stripped ends 12 feet long.	
<b>COMMUNICATION PORT ACCESSORIES</b>		
USB-RS232	USB to RS232 converter.	
USB-RS485	USB to RS485 converter.	
<b>MODBUS INTERFACE ACCESSORIES</b>		
ECS803-1	RJ45 shielded Y-adapter (Passive TAP).	
TDG1026-8C	RJ45 Modular Coupler.	
MOD27T	RJ45 Line Terminator (100 Ohm 0.25 W).	
JMOD4S-1	RJ45 Splitter fully shielded (5xRJ45, 1 input 4 outputs).	
TRD815BL-2	Category 5E Patch Twisted Pair Cable, RJ45 / RJ45, Blue 2.0 feet.	
TRD815BL-10	Category 5E Patch Twisted Pair Cable, RJ45 / RJ45, Blue 10.0 feet.	
TRD815BL-25	Category 5E Patch Twisted Pair Cable, RJ45 / RJ45, Blue 25.0 feet.	

TABLE 29 - DPC SPECIFICATIONS

<b>FLOW MEDIUM:</b>	Please note that DPC Mass Flow Controllers are designed to work only with clean, non-corrosive gases. Never try to control flow rates of liquids with any DPC.
<b>CALIBRATIONS:</b>	Performed at standard conditions [14.7 psia (101.4 kPa) and 70 °F (21.1 °C)] unless otherwise requested or stated.
<b>ENVIRONMENTAL (PER IEC 664):</b>	Installation Level II; Pollution Degree II.
<b>FLOW ACCURACY (INCLUDING LINEARITY):</b>	±(0.5% RD + 0.2% FS) at calibration temperature and pressure conditions after tare.
<b>REPEATABILITY:</b>	±0.2% of full scale.
<b>FLOW TEMPERATURE COEFFICIENT:</b>	0.05% of full scale/ °C or better.
<b>FLOW PRESSURE COEFFICIENT:</b>	0.01% of full scale/psi (6.895 kPa) or better.
<b>TYPICAL FLOW RESPONSE TIME:</b>	Default 150 ms (adjustable). <sup>1</sup>
<b>INSTRUMENT WARM-UP TIME:</b>	< 5 seconds.
<b>MAXIMUM CONTROLLABLE FLOW RANGE:</b>	133% Full Scale.
<b>OPERATING RANGE / TURNDOWN RATIO:</b>	0.5% to 100% Full Scale / 200:1.
<b>MASS REFERENCE CONDITIONS STP):</b>	70 °F & 14.696 PSIA (other available on request).
<b>MAXIMUM INTERNAL GAS PRESSURE (STATIC):</b>	DPC07/17/37/47/57/67/77: 120 PSIG DPC04/14: 50 PSIG
<b>MAXIMUM INSTANTANEOUS DIFFERENTIAL PRESSURE ACROSS DIFFERENTIAL SENSOR:</b>	DPC07/17/37/47/57/67/77: 12 PSID DPC04/14: 9.75 PSID
<b>PROOF PRESSURE:</b>	DPC07/17/37/47/57/67/77: 145 PSIG DPC04/14: 50 PSIG
<b>VALVE TYPE:</b>	Normally Closed.
<b>VALVE MAXIMUM OPERATING PRESSURE (WITH UPSTREAM CONFIGURATION)</b>	DPC04/07/14/17: (<2 sL/min) - 150 PSIG DPC17: (2 ÷ 5 sL/min) - 100 PSIG DPC17: (5 ÷ 20 sL/min) - 50 PSIG DPC37/47: 50 PSIG DPC57/67/77: 50 PSIG
<b>OPERATING TEMPERATURE:</b>	-10 to +60 °C (14 to 140 °F).
<b>MOUNTING ATTITUDE SENSITIVITY:</b>	None.
<b>RELATIVE GAS HUMIDITY RANGE:</b>	0 to 100% (Non -Condensing).
<b>INGRESS PROTECTION:</b>	IP40.
<b>ANALOG OUTPUT SIGNALS:</b>	Linear 0-5 Vdc (3000 ohms min. load impedance); Linear 0-10 Vdc (5000 ohms min. load impedance); Linear 4-20 mA (550 ohms maximum loop resistance) with power supply >= 14Vdc. Maximum noise 10mV peak to peak (for 0-5/0-10 Vdc output).
<b>ANALOG SET POINT INPUT SIGNALS</b>	Linear 0-5 Vdc, 0-10Vdc (100K input impedance). Linear 4-20mA (250 Ohm input impedance).
<b>TRANSDUCER INPUT POWER:</b>	12 to 26 Vdc, 150 mV maximum peak to peak output noise. Power consumption: 250 mA maximum for DPC04/07/14/17, 300mA maximum for DPC37/47. 24 to 26 Vdc for DPC57/67/77 (Power consumption: 650 mA maximum) circuit board have built-in polarity reversal protection, 300mA (750mA for DPC57/67/77) resettable fuse provide power input protection.
<b>DIGITAL OUTPUT SIGNALS <sup>2</sup>:</b>	Standard RS-232 or RS-485 (user selectable). Optional Modbus over isolated RS-485 transceiver.
<b>**MATERIALS FLUID CONTACT:</b>	316 stainless steel, 416 stainless steel, high temperature polyamide, alumina ceramic, poxy, silicone, glass, gold. Viton <sup>®</sup> O-rings.

1. For DPC with full scale 20 sml/min and lower the response time may be slightly longer.

2. Digital Signal provide access to Mass Flow, Volumetric Flow, Pressure, Temperature, Totalizers, Alarms.

\*\*The selection of materials of construction, is the responsibility of the customer. The company accepts no liability.

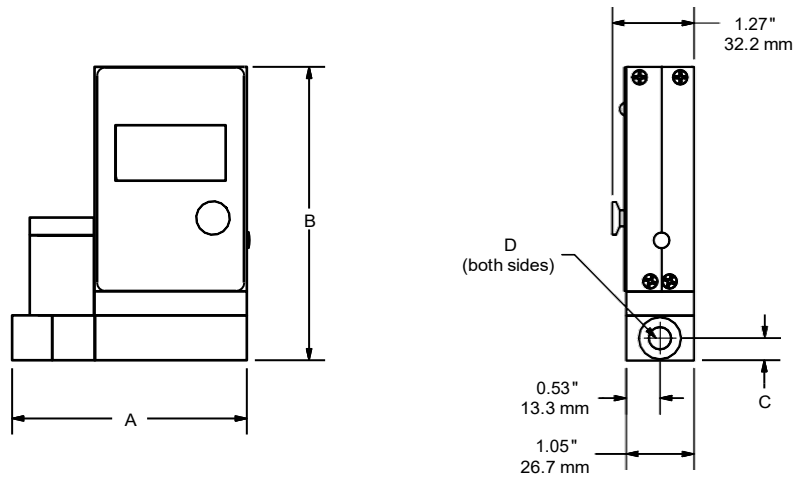

**DPC04/14 and DPC07/17  
Dimensional Drawing**

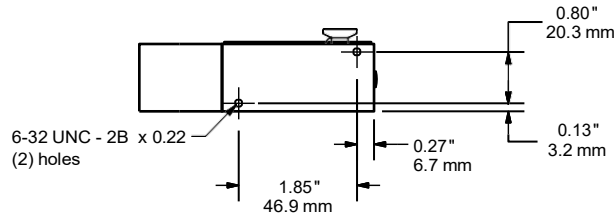

	<b>A</b>	<b>B</b>	<b>C</b>	<b>D</b>
<b>DPC04 / 07</b>	3.68" (93.4 mm)	4.58" (116.2 mm)	0.34" (8.5 mm)	10-32 UNF
<b>DPC14</b>	3.85" (97.7 mm)	4.84" (122.8 mm)	0.42" (10.7 mm)	1/4 NPT
<b>DPC17</b>	3.66" (92.9 mm)	4.40" (111.8 mm)	0.35" (8.9 mm)	1/8 NPT

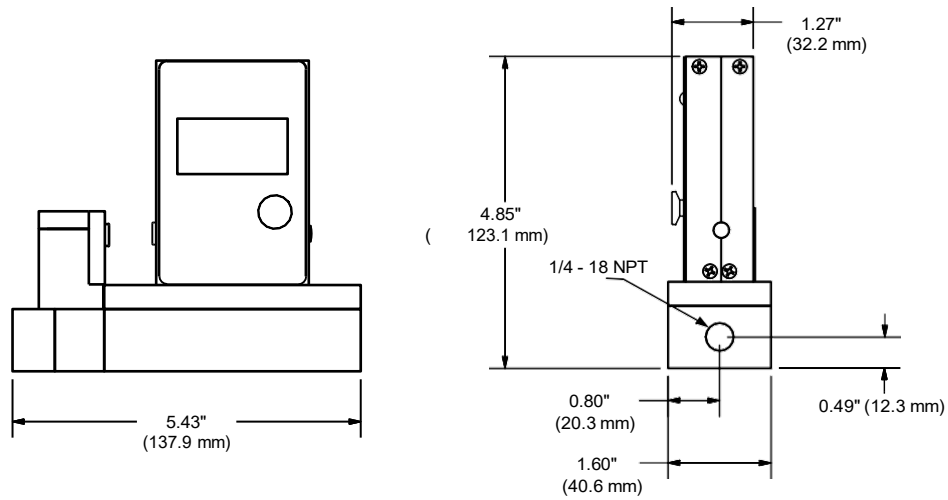

8-32 UNC - 2B x 0.30

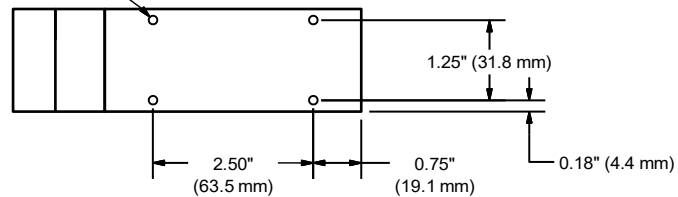

**DPC37 and DPC47  
Dimensional**

NOTE: Aalborg® reserves the right to change designs and dimensions at its sole discretion at any time without notice. For certified dimensions please contact Aalborg®.

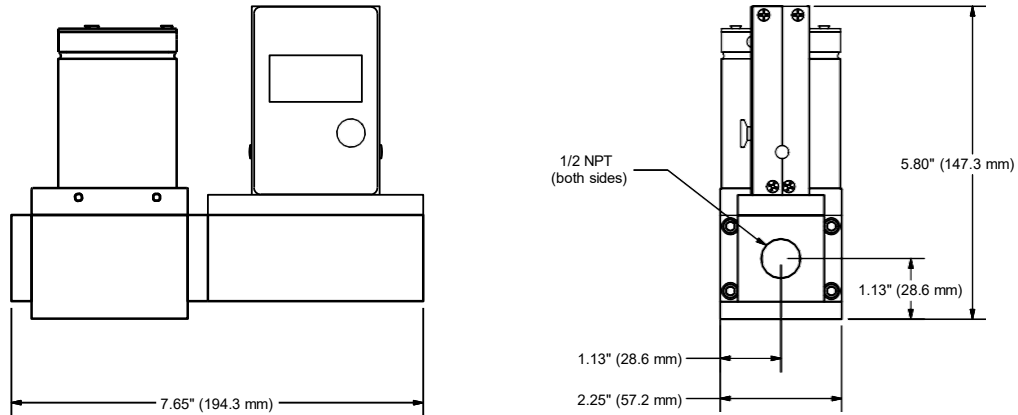

DPC 57  
Dimensional  
Drawing

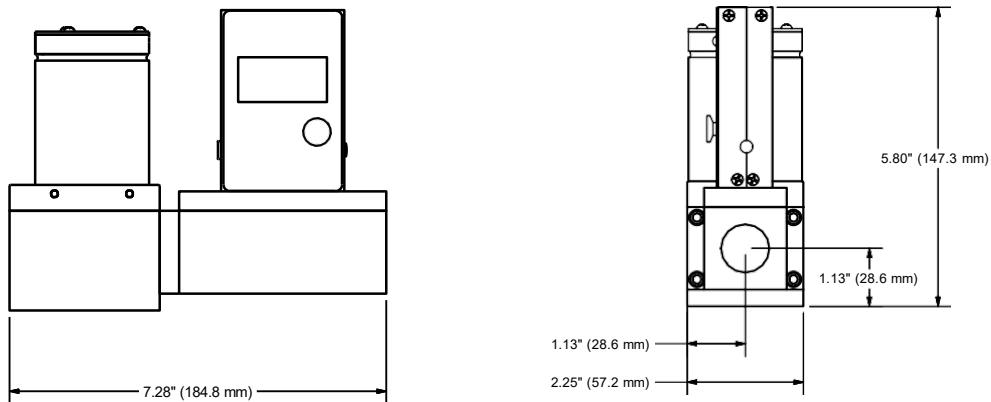
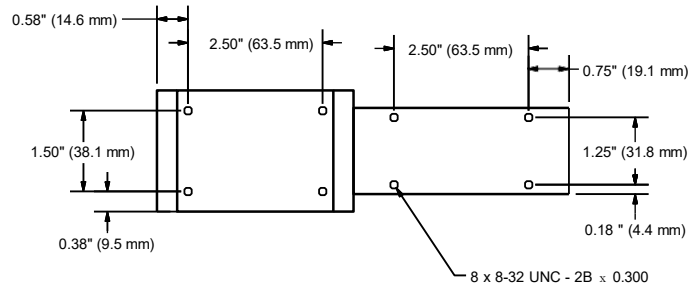

DPC67 and DPC77  
Dimensional  
Drawing

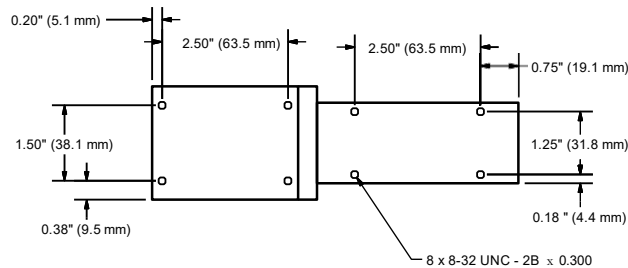

NOTE: Aalborg® reserves the right to change designs and dimensions at its sole discretion at any time without notice. For certified dimensions please contact Aalborg®.