

Technical Data for MC-Series Mass Flow Controllers

0.5 sccm full scale through 5 sccm full scale

Standard specifications. Consult Analyt-MTC for available options.

SENSOR AND CONTROL PERFORMANCE	
Mass Flow Accuracy at calibration conditions ¹	±0.8% of reading and ±0.2% of full scale
High Accuracy Option ¹	±0.4% of reading and ±0.2% of full scale Available for ≥5 SCCM models
Repeatability (2σ)	±(0.2% of reading + 0.02% of full scale)
Steady State Control Range ²	0.01–100% of full scale
Typical Control Response Time	100–4000 ms to 63% of step change (T63), user adjustable
Valve Function	Normally Closed
Temperature Sensitivity	Mass flow zero and span shift: 0.02% of full scale per °C from 25°C
Pressure Sensitivity	Mass flow zero and span shift: ±(0.08% of reading + 0.02% of full scale) per atm from calibration conditions
Operating Temperature Range	–10–60°C (expanded range available)
Temperature Accuracy	±0.75°C
Operating Pressure Full Scale	160 PSIA (additional options available)
Pressure Accuracy above 1 atm	±0.5% of reading
Pressure Accuracy below 1 atm	±0.07 PSIA
Totalizer Volume Uncertainty	±0.5% of reading in additional uncertainty
Sensor Response Time	<1 ms
Typical Indication Response Time ³	100–1000 ms (flow rate dependent)
Typical Warm-Up Time	<1 s

1 Stated accuracy is after tare under equilibrium conditions.

Extreme gas behavior (especially near state boundaries) can introduce additional flow uncertainties.

2 Achievable steady state control may be limited by user-configurable PID tuning and process conditions.

Dynamic control performance is also limited by control response time, which may vary with the flow rate.

3 Indication response time includes user adjustable averaging up to 255 ms.

MECHANICAL	
Minimum Operating Pressure	11.5 PSIA common mode pressure (lower operating pressures available). Differential pressure must exceed model pressure drop, see below for details.
Maximum Operating Pressure	Damage possible above 175 PSIA common mode pressure. Damage possible above 75 PSID differential pressure.
Ingress Protection	IP40 (consult Analyt-MTC for weatherproofing options)
Humidity Range	0–95%, non-condensing
Wetted Materials	302 / 303 / 304 / 430FR stainless steel, Viton®, heat-cured silicone rubber, polyamide, heat-cured epoxy, alumina, gold, brass, silicon, glass

COMMUNICATIONS	
Analog I/O Options	4–20 mA, 0–5 VDC, 1–5 VDC, 0–10 VDC
Digital I/O Options	RS-232 Serial by default RS-485 Serial, Modbus RTU (over RS-232 or RS-485), Modbus TCP/IP, DeviceNet, EtherCAT, EtherNet/IP, Profibus
Electrical Connection Options	6 pin locking, 8 pin mini-DIN, 8 pin M12, DB-9, DB-15
Power Requirements ⁴	12–24 VDC, 250 mA (290 mA if equipped with 4–20 mA output)
Digital Data Update Rate ⁴	40 Hz at 19200 baud
Analog Data Update Rate ⁴	1 kHz
Display Update Rate	10 Hz
Analog Signal Accuracy	±0.1% of full scale additional uncertainty

4 Consult the individual operating bulletins for specific industrial protocol power requirements and data transmission specifications.

Technical Data for MC-Series Mass Flow Controllers

0.5 sccm full scale through 5 sccm full scale

Standard specifications. Consult Analyt-MTC for available options.

FEATURES	
STP Reference Conditions	25°C and 1 atm (default), user configurable
NTP Reference Conditions	0°C and 1 atm (default), user configurable
Monochrome LCD or Color TFT Display with integrated touchpad	Simultaneously displays mass flow, volumetric flow, temperature, setpoint, and pressure
Gas Select™	98 user selectable gases stored internally. Each gas optimized to match NIST's REFPROP 10 gas property calculations across the operating temperature and pressure ranges for highest accuracy.
COMPOSER™	20 user definable gas mixes. Each mix may have up to 5 gases with 0.01% precision.

RANGE-SPECIFIC TECHNICAL DATA			
Full scale flow	Pressure drop at full scale flow ⁵	Process connections ⁶	Mount tap size
0.5 sccm	1.0 PSID	M5 female (10-32 compatible) ⁷	2× 8-32 UNC 0.175 in [4.45 mm]
1 sccm–5 sccm	2.0 PSID	M5 female (10-32 compatible) ⁷	2× 8-32 UNC 0.175 in [4.45 mm]

⁵ Default valve venting air to atmosphere. Lower pressure drops and other valves available, including our WHISPER-Series mass flow controllers.

⁶ Consult Analyt-MTC for available process connection options, such as: Compression, face seal, push-to-connect, BSPP, SAE, or Swagelok (including tube, VCO, and VCR).

⁷ Shipped with Buna-N O-Ring face seal to 1/8" female NPT fittings.

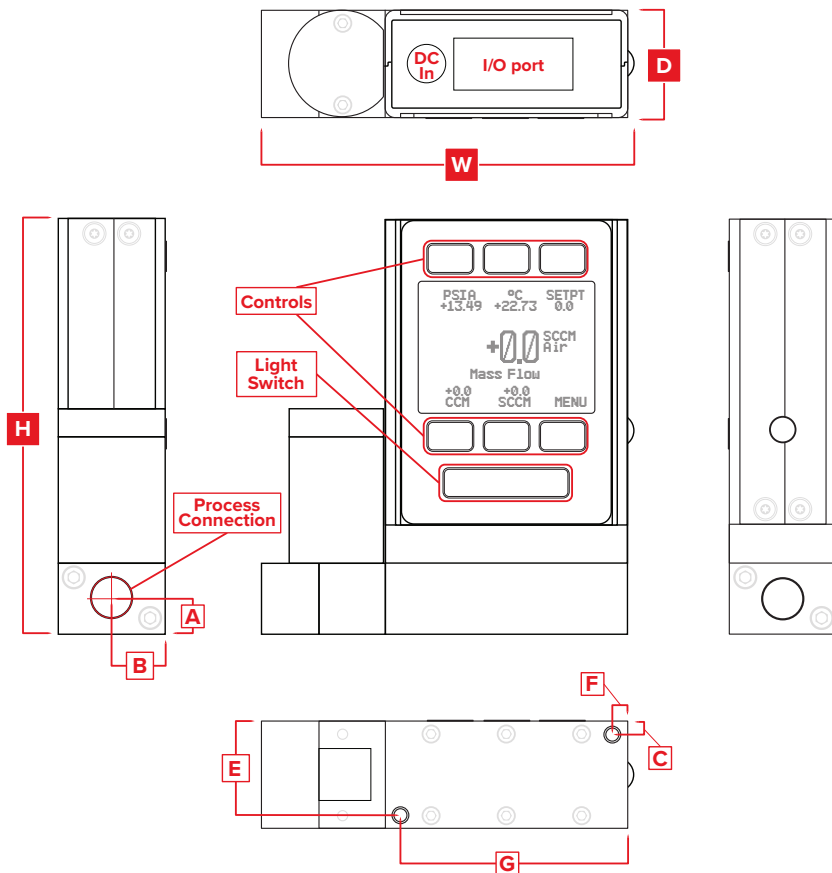

Representative Example

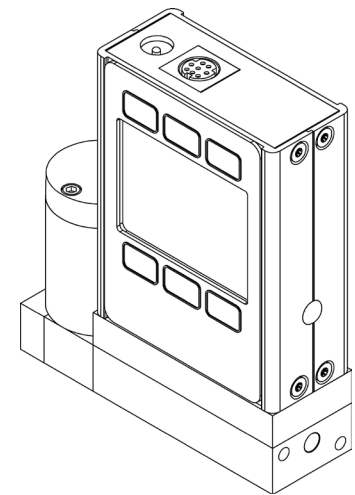

0.5 sccm

DIMENSIONS										
Full scale flow	Weight	Height	Width	Depth	A	B	C	E	F	G
0.5–5 sccm	≈ 1.1 lb	3.897 in	3.338 in	1.050 in	0.336 in	0.525 in	0.125 in	0.925 in	0.150 in	2.225 in
	≈ 0.5 kg	98.98 mm	84.79 mm	26.67 mm	8.53 mm	13.34 mm	3.18 mm	23.50 mm	3.81 mm	56.52 mm