

# Technical Data for MC-Series Mass Flow Controllers

50 SLPM full scale through 5000 SLPM full scale

Standard specifications. Consult Analyt-MTC for available options.



076315545

info@analyt-mtc.com

SENSOR AND CONTROL PERFORMANCE	
Mass Flow Accuracy at calibration conditions <sup>1</sup>	±0.8% of reading and ±0.2% of full scale
High Accuracy Option <sup>1</sup>	±0.4% of reading and ±0.2% of full scale Available for ≤500 SLPM models
Repeatability (2σ)	±(0.2% of reading + 0.02% of full scale)
Steady State Control Range <sup>2</sup>	0.01–100% of full scale
Typical Control Response Time	30–150 ms to 63% of step change (T63), user adjustable
Valve Function	Normally Closed
Temperature Sensitivity	Mass flow zero and span shift: 0.02% of full scale per °C from 25°C
Pressure Sensitivity	Mass flow zero and span shift: ±(0.08% of reading + 0.02% of full scale) per atm from calibration conditions
Operating Temperature Range	–10–60°C (expanded range available)
Temperature Accuracy	±0.75°C
Operating Pressure Full Scale	160 PSIA (additional options available)
Pressure Accuracy above 1 atm	±0.5% of reading
Pressure Accuracy below 1 atm	±0.07 PSIA
Totalizer Volume Uncertainty	±0.5% of reading in additional uncertainty
Sensor Response Time	<1 ms
Typical Indication Response Time <sup>3</sup>	65–255 ms (flow rate dependent)
Typical Warm-Up Time	<1 s

- 1** Stated accuracy is after tare under equilibrium conditions.  
Extreme gas behavior (especially near state boundaries) can introduce additional flow uncertainties.
- 2** Achievable steady state control may be limited by user-configurable PID tuning and process conditions.  
Dynamic control performance is also limited by control response time, which may vary with the flow rate.
- 3** Indication response time includes user adjustable averaging up to 255 ms.

MECHANICAL	
Minimum Operating Pressure	11.5 PSIA common mode pressure (consult Analyt-MTC for lower operating pressures). Differential pressure must exceed model pressure drop, see below for details.
Maximum Operating Pressure	Damage possible above 175 PSIA common mode pressure. Damage possible above 75 PSID differential pressure.
Ingress Protection	IP40 (consult Analyt-MTC for weatherproofing options)
Humidity Range	0–95%, non-condensing
Wetted Materials	302 / 303 / 304 stainless steel, Viton®, heat-cured silicone rubber, polyamide, heat-cured epoxy, alumina, gold, silicon, glass <b>MCP:</b> Add brass and 430FR stainless steel <b>MCR/MCRH:</b> Add 410 stainless steel

# Technical Data for **MC-Series** Mass Flow Controllers

**50 SLPM** full scale through **5000 SLPM** full scale

Standard specifications. Consult Analyt-MTC for available options.



COMMUNICATIONS	
Analog I/O Options	4–20 mA, 0–5 VDC, 1–5 VDC, 0–10 VDC
Digital I/O Options	RS-232 Serial by default RS-485 Serial, Modbus RTU (over RS-232 or RS-485), Modbus TCP/IP, DeviceNet, EtherCAT, EtherNet/IP, Profibus
Electrical Connection Options	6 pin locking, 8 pin mini-DIN, 8 pin M12, DB-9, DB-15
Power Requirements <sup>4</sup>	<b>MCP (miniature valve):</b> 12–24 VDC, 250 mA <b>MCR (Rolamite valve):</b> 24 VDC, 1 A <b>MCRH (dual Rolamite valves):</b> 24–30 VDC, 2 A Add 40 mA if equipped with 4–20 mA output
Digital Data Update Rate <sup>4</sup>	40 Hz at 19200 baud
Analog Data Update Rate <sup>4</sup>	1 kHz
Display Update Rate	10 Hz
Analog Signal Accuracy	±0.1% of full scale additional uncertainty

<sup>4</sup> Consult the individual operating bulletins for specific industrial protocol power requirements and data transmission specifications.

FEATURES	
STP Reference Conditions	25°C and 1 atm (default), user configurable
NTP Reference Conditions	0°C and 1 atm (default), user configurable
Monochrome LCD or Color TFT Display with integrated touchpad	Simultaneously displays mass flow, volumetric flow, temperature, setpoint, and pressure
Gas Select™	98 user selectable gases stored internally. Each gas optimized to match NIST's REFPROP 10 gas property calculations across the operating temperature and pressure ranges for highest accuracy.
COMPOSER™	20 user definable gas mixes. Each mix may have up to 5 gases with 0.01% precision.

RANGE-SPECIFIC TECHNICAL DATA				
Full scale flow	Type	Pressure drop at full scale flow <sup>5</sup>	Process connections <sup>6</sup>	Mount tap size
50 SLPM	MCP	5.0 PSID	¼" NPT female	4× 8-32 UNC 0.375 in [9.53 mm]
100 SLPM	MCP	15.5 PSID	¼" NPT female	4× 8-32 UNC 0.375 in [9.53 mm]
250 SLPM	MCR	2.4 PSID	½" NPT female	4× 8-32 UNC 0.328 in [8.33 mm]
500 SLPM	MCR	6.5 PSID	¾" NPT female	4× 8-32 UNC 0.328 in [8.33 mm]
1000 SLPM	MCR	14.0 PSID	¾" NPT female	4× 8-32 UNC 0.328 in [8.33 mm]
1500 SLPM	MCR	17.0 PSID	¾" NPT female	4× 8-32 UNC 0.328 in [8.33 mm]
2000 SLPM	MCR	28.6 PSID	¾" NPT female (1¼" NPT connection available)	4× 8-32 UNC 0.330 in [8.38 mm]
3000 SLPM	MCR	16.8 PSID	1¼" NPT female	4× 8-32 UNC 0.330 in [8.38 mm]
5000 SLPM	MCRH	14.1 PSID	2" NPT female	4× 8-32 UNC 0.300 in [7.62 mm]

<sup>5</sup> Default valve venting air to atmosphere. Lower pressure drops and other valves available, including our MLW-Series mass flow controllers.

<sup>6</sup> Consult Analyt-MTC for available process connection options, such as: Compression, face seal, push-to-connect, BSPP, SAE, or Swagelok (including tube, VCO, and VCR).

# Technical Data for MC-Series Mass Flow Controllers

50 SLPM full scale through 5000 SLPM full scale

Standard specifications. Consult Analyt-MTC for available options.



## Representative Examples

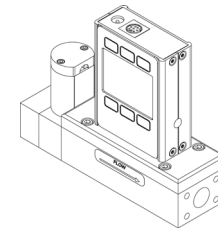

100 SLPM

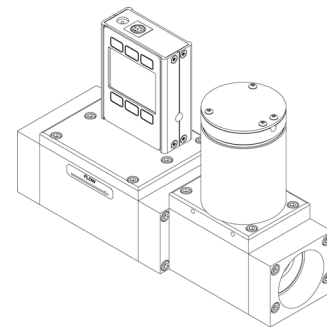

2000 SLPM

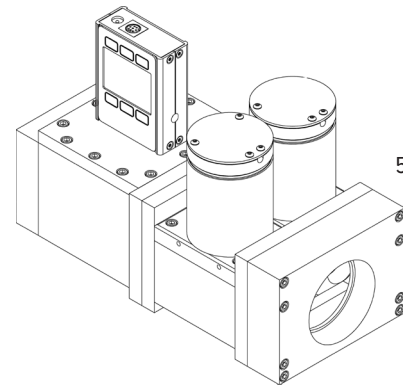

5000 SLPM

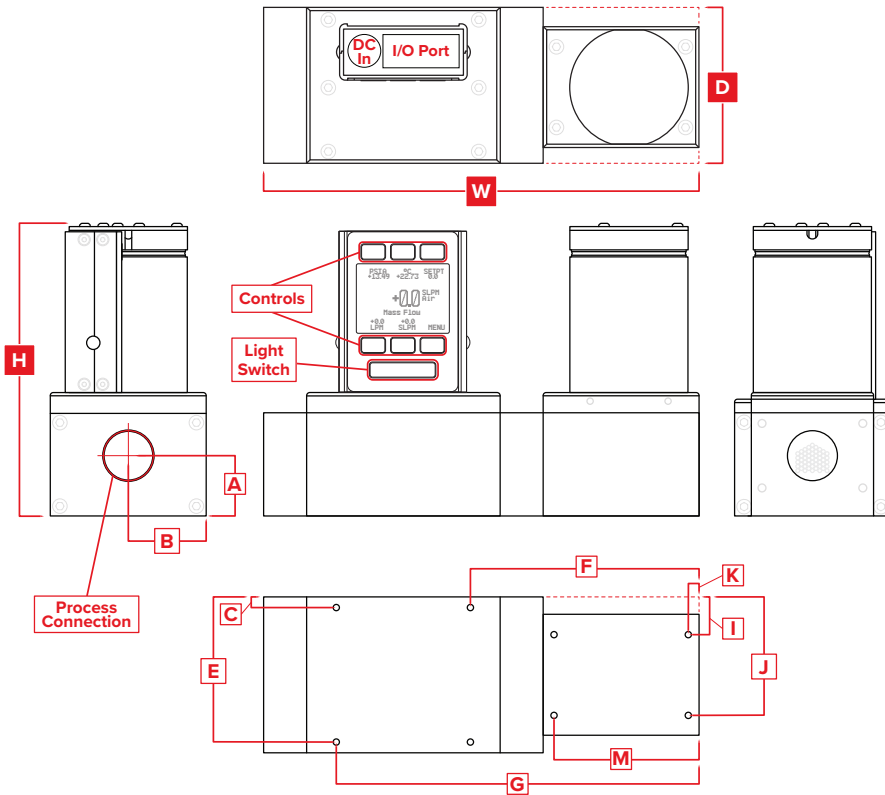

## DIMENSIONS

Full scale flow	Type	Weight	Height	Width	Depth	A	B	C	E	F	G	I	J	K	M
50–100 SLPM	MCP	≈ 9.0 lb	4.367 in	5.408 in	1.600 in	0.500 in	0.800 in	0.175 in	1.425 in	0.750 in	3.250 in	—	—	—	—
		≈ 4.1 kg	110.92 mm	137.36 mm	40.64 mm	12.70 mm	20.32 mm	4.45 mm	36.20 mm	19.05 mm	82.55 mm	—	—	—	—
250 SLPM	MCR	≈ 9.0 lb	5.495 in	7.650 in	2.250 in	1.120 in	1.125 in	0.175 in	1.425 in	4.400 in	6.900 in	0.375 in	1.875 in	0.575 in	3.075 in
		≈ 4.1 kg	139.57 mm	194.31 mm	57.15 mm	28.45 mm	28.58 mm	4.45 mm	36.20 mm	111.76 mm	175.26 mm	9.53 mm	47.63 mm	14.61 mm	78.11 mm
500–1000 SLPM	MCR	≈ 9.0 lb	5.495 in	7.275 in	2.250 in	1.120 in	1.125 in	0.175 in	1.425 in	4.025 in	6.525 in	0.375 in	1.875 in	0.200 in	2.700 in
		≈ 4.1 kg	139.57 mm	184.79 mm	57.15 mm	28.45 mm	28.58 mm	4.45 mm	36.20 mm	102.24 mm	165.74 mm	9.53 mm	47.63 mm	5.08 mm	68.58 mm
2000 SLPM	MCR	≈ 12.0 lb	5.495 in	8.100 in	2.900 in	1.120 in	1.450 in	0.200 in	2.700 in	4.250 in	6.750 in	0.700 in	2.200 in	0.200 in	2.700 in
		≈ 5.4 kg	139.57 mm	205.74 mm	73.66 mm	28.45 mm	36.83 mm	5.08 mm	68.58 mm	107.95 mm	171.45 mm	17.78 mm	55.88 mm	5.08 mm	68.58 mm
3000 SLPM	MCR	≈ 12.0 lb	5.495 in	8.900 in	2.900 in	0.960 in	1.450 in	0.200 in	2.700 in	5.050 in	7.550 in	0.700 in	2.200 in	1.000 in	3.500 in
		≈ 5.4 kg	139.57 mm	226.06 mm	73.66 mm	24.38 mm	36.83 mm	5.08 mm	68.58 mm	128.27 mm	191.77 mm	17.78 mm	55.88 mm	25.40 mm	88.90 mm
5000 SLPM	MCRH	≈ 28.0 lb	6.267 in	9.800 in	3.840 in	1.450 in	1.920 in	0.295 in	3.545 in	5.958 in	8.455 in	—	—	—	—
		≈ 12.7 kg	159.18 mm	248.92 mm	97.54 mm	36.83 mm	48.77 mm	7.49 mm	90.04 mm	151.32 mm	214.76 mm	—	—	—	—