



## INTERCHANGEABLE

Designed for low flow rates, the **Model P** flow meter is a precision instrument embodying the inherent simplicity, versatility and economy of the classical rotameter. It is particularly suitable for metering carrier gases in chromatography, indicating and controlling gases in manufacturing processes, liquid and gas measurement in laboratories, pilot plants, flow and level indicating, etc.

Shipped completely assembled, flow meters include standard mounting fittings in a choice of materials, side plates, thick protective magnifying front shield and back plate, optional built-in control valve, and flow tubes selected from the Flow Capacities tables. Panel mounting style is convertible to bench mounting through the use of the optional acrylic tripod. The tripod has a built-in spirit leveler and leveling screws.

For multiple tube meters see pages 17 and 18.

### design features

- ✓ Rib-guided or fluted metering tubes facilitate stable, accurate readings.
- ✓ Magnifier lens in front shield to enhance reading resolution.
- ✓ Interchangeability of flow tubes and floats.
- ✓ Ease of installation and exchange of flow tubes.
- ✓ “Non-rotating” adapter feature - glass flow tubes are prevented from turning during the tightening phase of the assembly procedure.
- ✓ OPTIGRAD™ scales minimize parallax and eye fatigue.
- ✓ Chemical compatibility.
- ✓ Simple means of panel mounting.

150 mm Meter with CV™ Valve



65 mm Meter with MFV™ Valve



## BUILT-IN VALVES

Meters are available with built-in needle valves (CV™), high precision metering valves (MFV™) with “non-rising stems”, or with no valves. The higher cost of MFV™ valves is justified whenever high sensitivity control and resolution are desirable particularly in conjunction with metering tubes of very low flow rates.

Generally, for gas metering it is recommended that valves are positioned at inlets (bottom) for liquids valves may be positioned either at inlets or outlets (top). For vacuum services, valves must be mounted at outlets. If unspecified at the time of ordering, meters will be shipped with valves mounted at the inlets.

Panel mounting is convertible to bench mounting through the use of an optional acrylic tripod base with spirit leveler (catalog No. TP1).

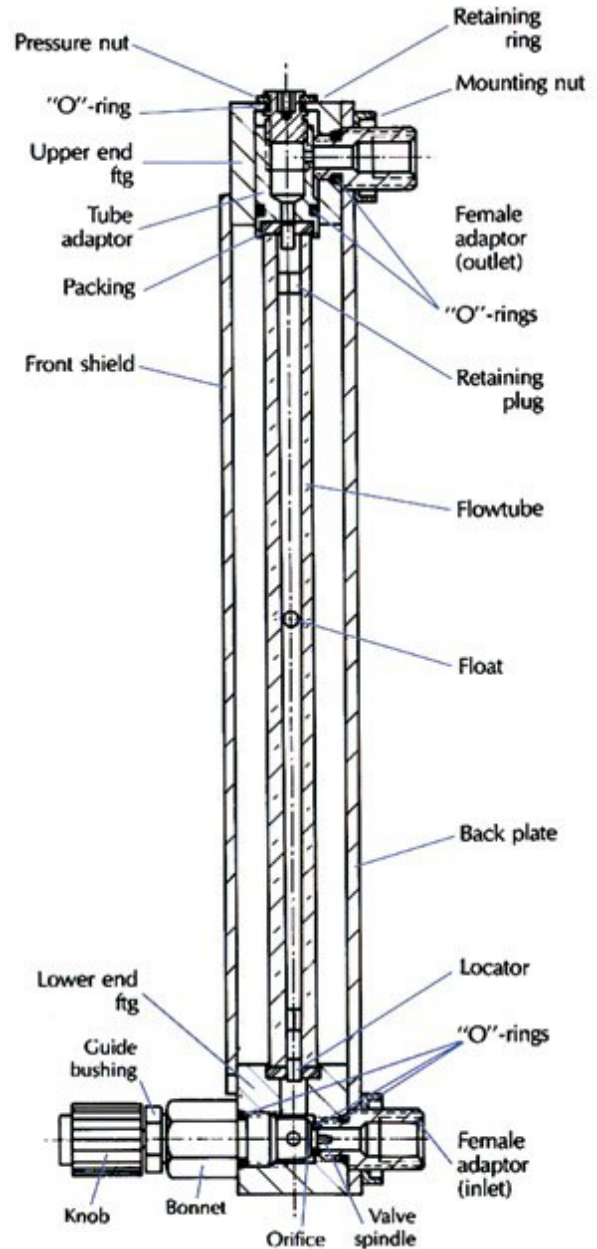

Assorted flow tubes may be used in conjunction with a single mounting frame, an apparent benefit in many laboratory applications.

### SPECIFICATIONS

**STANDARD ACCURACY** ±2% FS mm scales except 042 and 032 flow tubes. ±5% FS direct reading scales 042 and 032 flow tubes.

**CALIBRATED ACCURACY** ±1% FS optional.

**REPEATABILITY** ±0.25%.

**USEFUL FLOW RANGE** 10:1 minimum with one float and better than 20:1 with combination of two floats installed in meters.

#### MAXIMUM OPERATING PRESSURE

200 psig/13.8 bars.

#### MAXIMUM OPERATING TEMPERATURE

250 °F/ 121 °C.

### \*\*MATERIALS OF CONSTRUCTION

**FLOW TUBES** Heavy walled borosilicate glass.

**FLOATS** Glass, Sapphire, 316 Stainless Steel, Carboloy® and Tantalum.

#### CHOICE OF MOUNTING FITTINGS IN CONTACT WITH FLUIDS

- Aluminum, black anodized.
- Brass, chrome plated.
- 316 stainless steel.

**SIDE PANELS** Aluminum, black anodized.

**FRONT SHIELD** Lexan® with longitudinal magnifier lens for enhanced reading resolution.

**BACK PLATE** 1/8" thick white acrylics.

**O-RINGS AND PACKING** Buna® o-rings in aluminum/ brass model.

FKM o-rings in stainless steel meters.

**OPTIONAL** FKM PTFE FFKM and EPR.

**CONNECTIONS** 1/8" NPT female inlet and outlet connections.

**OPTIONAL** 1/4" FNPT, hose and compression fittings are available.

\*\*The selection of materials of construction, is the responsibility of the customer. The company accepts no liability.



## MULTIPLE TUBE FLOW METERS

The **Model Px** multiple tube flow meter line offers, the convenience and simplicity of 2, 3, 4, 5 and 6 tube meters, retaining most of the unique design features associated with single tube units. Multiple tube meters are available with 65mm or 150mm flow tubes same as used in single unit flow meters.

Px meters are convenient for applications where several streams of gases or liquids are to be metered in individual channels, or manifolded.

Shipped completely assembled, flow meters include standard mounting fittings in a choice of materials, side plates, thick protective front shield and back plate, optional built-in control valve, and flow tubes selected from the Flow Capacities tables.

Panel mounting style is convertible to bench mounting through the use of the optional acrylic tripod. The tripod has a built-in spirit leveler and leveling screws.

### design features

- ✓ Rib-guided or fluted metering tubes facilitate stable, accurate readings.
- ✓ Interchangeability of flow tubes and floats.
- ✓ Manifolding at inlet or outlet.
- ✓ Ease of installation and exchange of flow tubes.
- ✓ “Non-rotating” adapter feature - glass flow tubes are prevented from turning during the tightening phase of the assembly procedure.
- ✓ OPTIGRAD™ scales minimize parallax and eye fatigue.
- ✓ Chemical compatibility.
- ✓ Simple means of panel mounting.

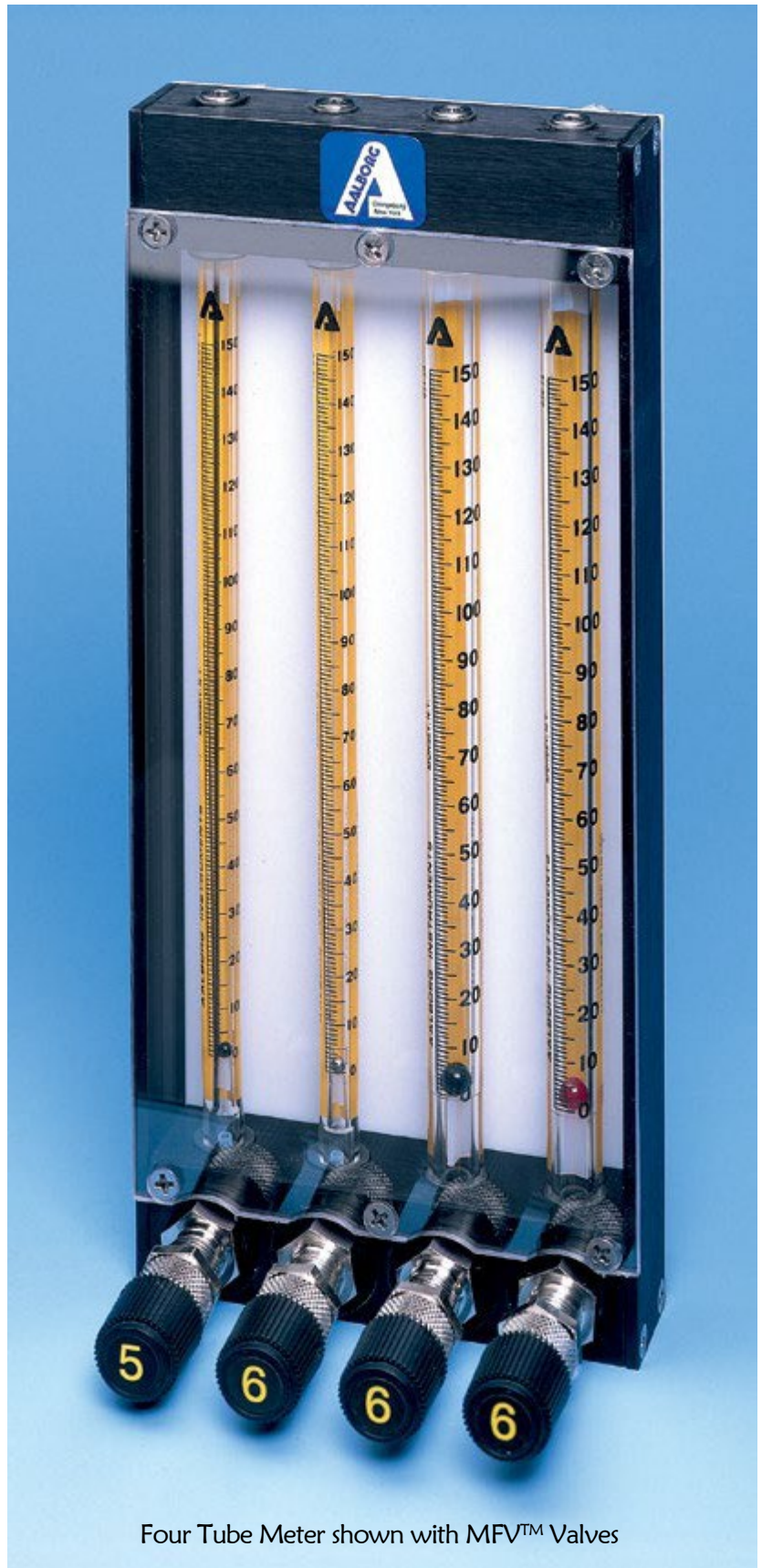

Four Tube Meter shown with MFV™ Valves



## BUILT-IN VALVES

Meters may be supplied with built-in needle valves (CV™), high precision metering valves (MFV™) with “non-rising stems”, or with no valves. Generally for gas metering, it is recommended that valves are positioned at inlets (bottom) for liquids valves may be positioned either at outlets (top) or inlets. For vacuum service, valves must be mounted at outlets. If unspecified at the time of ordering, meters will be shipped with valves mounted at inlets.

## MOUNTING DIMENSIONS

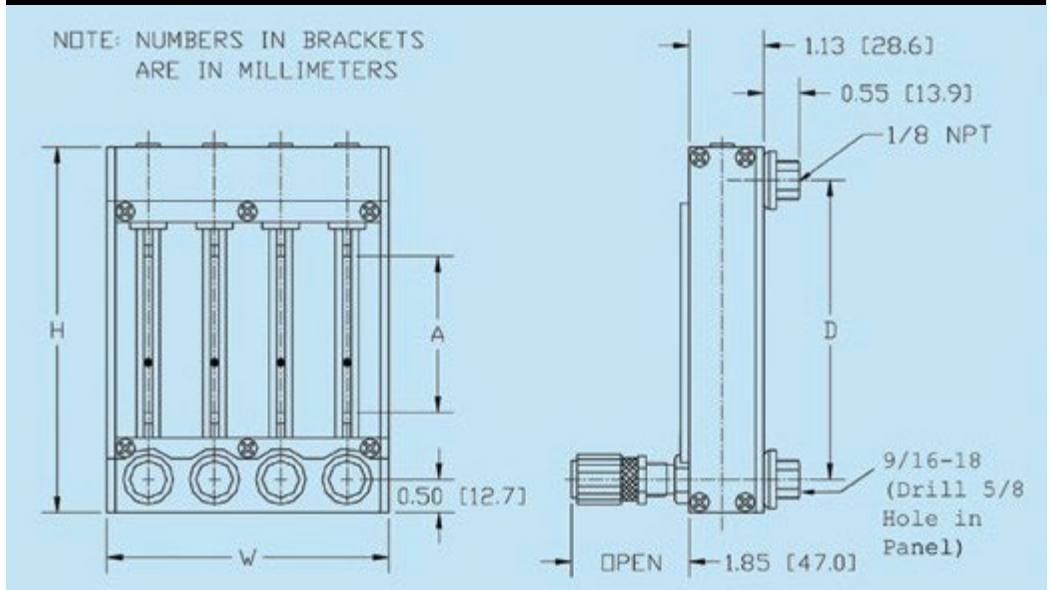

## SPECIFICATIONS

### STANDARD ACCURACY

±2% FS mm scales except 042 and 032 flow tubes.  
 ±5% FS direct reading scales 042 and 032 flow.  
 Conforming to ISA RP. 16-1.2.3  
*Specification 2-S-10. Manifoldd models excepted.*

### CALIBRATED ACCURACY

±1% FS optional.

### REPEATABILITY ±0.25%.

### USEFUL FLOW RANGE

10:1 minimum with one float. Better than 20:1 with combinations of two floats installed in meters.

### MAXIMUM OPERATING PRESSURE

200 psig/13.8 bars.

### MAXIMUM OPERATING TEMPERATURE

250 °F/ 121 °C.

## \*\*MATERIALS OF CONSTRUCTION

**FLOW TUBES** Heavy walled borosilicate glass.

### CHOICE OF MOUNTING FITTINGS IN CONTACT WITH FLUIDS

- a) Aluminum, black anodized.
- b) 316 Stainless Steel.

**SIDE PANELS** Aluminum, black anodized.

### FRONT SHIELD AND BACK PLATE

1/8" thick clear polycarbonate and white acrylics.

### O-RINGS AND PACKING

Buna® O-rings in aluminum model.  
 FKM O-rings in stainless steel meters.  
**OPTIONAL** FKM, PTFE/FFKM, EPR.

**CONNECTIONS** 1/8" NPT female inlet and outlet connections.

**OPTIONAL:** 1/4" FNPT, hose & compression fittings are available.

## FLOW PATTERNS AVAILABLE

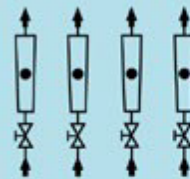

1. Parallel isolated channels

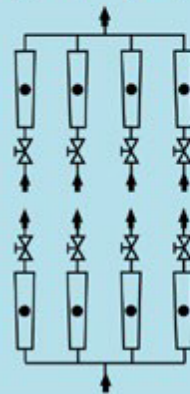

2. Parallel channels mixed in manifold

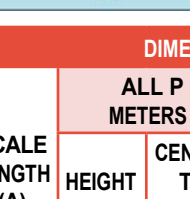

3. Single fluid entering exhausted separately

The built-in-valves are always installed in the end block opposite to the manifolded one.

Thus, if a meter is manifolded at the outlet, valves are installed at the inlets; if a meter is manifolded at the inlet, valves are installed at the outlets.

## DIMENSIONS FOR P STYLE METERS

SCALE LENGTH (A)	ALL P METERS		WIDTH (W)					
	HEIGHT (H)	CENTER TO CENTER (D)	1 TUBE	2 TUBE	3 TUBE	4 TUBE	5 TUBE	6 TUBE
65mm	5.500	4.500	1.250	2.250	3.250	4.250	5.250	6.250
150mm	9.813	8.813	1.250	2.250	3.250	4.250	5.250	6.250

\*\*The selection of materials of construction, is the responsibility of the customer. The company accepts no liability.