

USER'S GUIDE

HAZ-DUST IV™ REAL-TIME PERSONAL DUST MONITOR

MODEL HD-1004
DOC# HD40706

Environmental Devices Corporation
4 Wilder Drive Bldg. # 15
Plaistow, NH 03865

Phone: (603) 378-2112
(800) 234-2589

Fax: (603) 378-2113

E-mail: customerservice@hazdust.com

E-mail: technicalsupport@hazdust.com

Website: www.hazdust.com

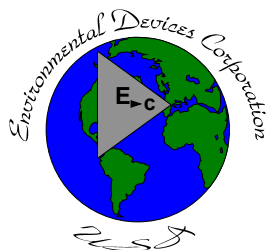

EDC

New technology for monitoring air quality

Haz-Dust IV™

User's Guide



Licenses, Copyrights and Trademarks

This documentation contains trade secrets and confidential information proprietary to Environmental Devices Corporation (EDC). The software supplied with the instrumentation, documentation and any information contained therein may not be used, duplicated or disclosed to anyone, in whole or in part, other than as authorized in a fully executed EDC End User License or with the express written permission of EDC.

© 1997 Environmental Devices Corporation. All rights reserved throughout the world.

Haz-Dust IVTM is a registered trademark of Environmental Devices Corporation. Other trademarks are the property of their respective holders.

Safety Notice

Repair of instrumentation supplied by Environmental Devices Corporation (EDC) should only be attempted by properly trained service personnel, and should only be conducted in accordance with the EDC system documentation. Do not tamper with this hardware. High voltages may be present in all instrument enclosures. Use established safety precautions when working with this instrument.

The seller cannot foresee all possible modes of operation in which the user may attempt to utilize this instrumentation. The user assumes all liability associated with the use of this instrumentation. The seller further disclaims any responsibility for consequential damages.

Warranty

Environmental Devices Corporation (EDC) warrants only non-expendable products, parts and labor, for a period of one year from date of shipment to the original purchaser. The warranty covers only product parts and labor that failed due to normal operation of the instrument and not due to abuse or negligence. The product will be delivered in accordance to its published specifications and free from defects in materials or workmanship.

Expendable products (battery, o-rings, tubing, disposable filter cassette, etc.) are warranted for a period of 90 days from receipt of shipment.

If a product fails to conform to this one year limited warranty it may be returned to the factory for repair or replacement of the defected part(s). EDC must be notified of all returning warranty repair products, either in writing or by telephone. Shipping and insurance cost will be prepaid by the purchaser. If unit is still under warranty EDC will pay for its return to the purchaser.

EDC makes no other express warranty and disclaims any implied warranty of fitness or merchantability.

Table of Contents

Chapter 1 - Introduction to the Haz-Dust IV.....	1-1
Introduction to the Haz-Dust IV.....	1-2
Overview of the Haz-Dust IV	1-4
Real-Time Dust Monitoring Principles	1-6
Features	1-7
Specifications	1-8
Components.....	1-9
Chapter 2 - Operating Parameters of the HAZ-DUST IV	2-1
Turning the Haz-Dust IV On and Off	2-2
Using the Menu	2-3
Setting the Alarm.....	2-4
Setting the Date and Time	2-5
Clearing the Memory.....	2-6
Chapter 3 - Operating the Haz-Dust IV	3-1
Selecting the Particle Size.....	3-2
Thoracic Dust Particulates.....	3-3
Respirable Dust Particulates.....	3-4
Inhalable Dust Particulates	3-5
Auto-Zero.....	3-7
Sampling.....	3-10
Custom Correction Factor on HD-1004.....	3-13
Location Codes.....	3-14
Reviewing Stored Data.....	3-15
Chapter 4 - DustComm Pro V.1.2.....	4-1
Introduction to DustComm Pro V.1.2	4-2
Installing DustComm Pro	4-3
Loading DustComm Pro.....	4-4
Menu Selections	4-5
File Menu Command	4-6
Downloading Data.....	4-8
DustComm Pro Window	4-11
Translating Data into ASCII Text File.....	4-14
Generating a Plot.....	4-15
Data Plot Menu Selections	4-16
Editing a Title.....	4-17
Applying a Correction Factor.....	4-18
Inability to Download.....	4-19
Chapter 5 - Maintenance	5-1
Checking the Calibration Span.....	5-2
Checking the Flow Rate	5-5
Adjusting the Flow Rate.....	5-7
Battery Maintenance.....	5-8
Cleaning the Sensor Optics	5-12
Appendix A - NIOSH/OSHA Particulate Air Monitoring Reference.....	A-1

Appendix B - Particle Size Selections.....B-1
Appendix C - Glossary of Terms.....C-1
Appendix D - Haz-Dust IV AccessoriesD-1

Chapter 1 - Introduction to the Haz-Dust IV

Chapter 1

Introduction to the Haz-Dust IV

Chapter Overview

Introduction This chapter gives a complete overview of the Haz-Dust IV.

This chapter:

- Introduces and describes Haz-Dust IV.
 - Explains operating principles of the Haz-Dust IV.
 - Identifies features, specifications and components of Haz-Dust IV.
-

In this chapter This chapter contains the following topics.

Topic	See Page
Introduction to the Haz-Dust IV	1-2
Overview of the Haz-Dust IV	1-4
Real-Time Dust Monitoring Principles	1-6
Features	1-7
Specifications	1-8
Components	1-9



Figure 1-1. Picture of the Haz-Dust IV.

Introduction to the Haz-Dust IV

Introduction

The Haz-Dust IV is the worlds first personal dust monitor to combine traditional filter techniques with real-time monitoring methods. These techniques combine to overcome limitations of all other dust monitoring products.



Figure 1-2. Diagram of the Haz-Dust IV.

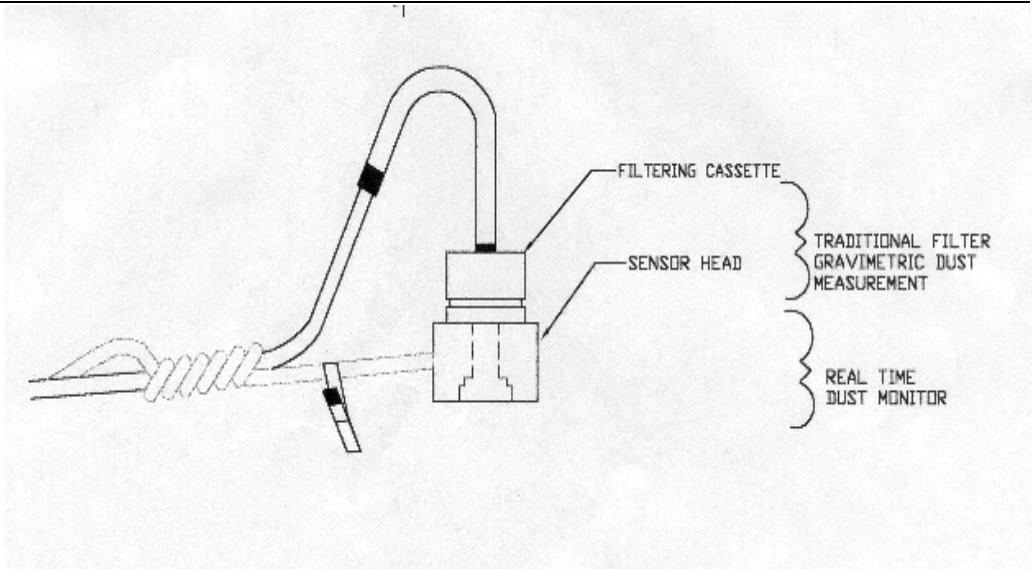

Figure 1-3. Diagram showing components used for both the traditional and real-time dust monitoring methods.

Continued on next page

Introduction to the Haz-Dust IV, Continued

Comparison of methods The traditional and real-time dust monitoring methods are described below.

Description of traditional method Air is drawn by a vacuum pump through a 25mm or 37mm diameter membrane filter. The fibers and particles collected on the membrane filter must be counted or weighed in a laboratory for further analysis.

Advantages of traditional method¹

- OSHA compliance reference method.
- High level of specificity and accuracy.
- Collection of dust particles, which are available for further chemical analysis.

Description of real-time method Dust particles are drawn into the sensor head and are detected once every second. Dust concentrations are instantaneously calculated and displayed on the Haz-Dust IV's LCD. All data points are stored in memory for later analysis.

Advantages of real-time method¹

- Immediate estimations of the concentration of a contaminant, permitting on-site evaluations.
- Provision of permanent 24-hour records of contaminant concentrations using continuous monitors.
- Internal audible alarm to warn workers of approaching hazardous situations.
- Reduction of number of manual tests.
- Reduction of number of laboratory analyses.
- Provision of more convincing evidence for presentation at hearings and litigation proceedings.
- Reduced cost of obtaining individual results.

¹ "The Industrial Environment - It's Evaluation & Control", U.S. Department of Health & Human Services, DCD, NIOSH, ©1973.

Overview of the Haz-Dust IV

Ease of use

- The user controls all functionality and programming using menus displayed on a high contrast LCD.
 - The compact unit attaches to the workers waist allowing for flexibility during on-site monitoring.
 - A detached sensor head easily attaches to the worker for true breathing zone measurements.
 - A user adjustable alarm can be preset to alert the worker of approaching threshold limits.
-

General Information

- The LCD displays real-time concentration in milligram per cubic meter (mg/m^3) in accordance with OSHA Reference Methods.
 - Statistical information of TWA, STEL, Max and Min levels can be viewed instantly.
 - The Haz-Dust IV is calibrated using Arizona Road Dust (ARD) against NIOSH method 0600 for Respirable dust with a $\pm 10\%$ accuracy.
 - The calibration of the Haz-Dust IV can be adjusted to compensate for Thoracic, Respirable, or Inhalable changes in particle composition and distribution.
-

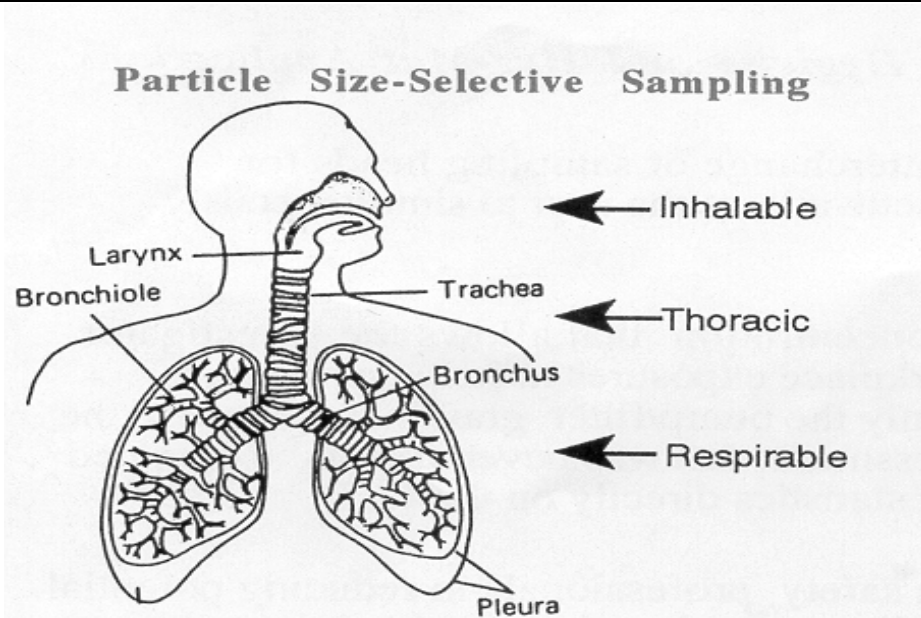

Figure 1-4. Diagram showing breathing zones of Inhalable, Thoracic, and Respirable dust particles.

Continued on next page

Overview of the Haz-Dust IV, Continued

DustComm Pro Software The Haz-Dust IV comes equipped with DustComm Pro software, which allows internally stored data to be downloaded to a PC for further analysis.

DustComm Pro software is designed for more detailed analysis of sampled data. Pull down menus provides a user-friendly environment to store and analyze data and print management ready reports.

Data can easily be exported in comma-delimited ASCII Text Files importable into spreadsheet programs such as Microsoft Excel.

The data plots provided with DustComm Pro enable:

- Detailed statistical analysis.
 - Creation of graphics and charts.
 - Mathematical correction of particle characteristics when aerosol significantly differs from calibration dust.
-

Features

Introduction

The Haz-Dust IV provides a unique combination of features to provide superior data quality, ease of use, and flexibility to the user. Below is a partial list of distinctive features.

Real-time display of

- Particulate exposure levels.
 - TWA, STEL, Min, and Max levels.
 - Thoracic, Respirable or Inhalable Particulate Mass.
 - True breathing zone measurements.
 - Stored data by location code.
-

Functional features

- Calibration to NIOSH methods for lung damaging particles.
 - In line concurrent filter samples for gravimetric analysis.
 - High sensitivity of 0.01 to 200 mg/m³.
 - Interchangeable size-selective sampling inlets.
 - Internal air sampling pump.
 - Simple cleaning of sensor hardware.
 - Easy user access to rechargeable battery and internal filter.
-

Operational features

- On-screen programming of sampling and data storage parameters.
 - Real-time clock.
 - User selectable audible alarm.
 - In-field zero and span check of instrument calibration.
-

Data management

- Choice of 1 second, 1 minute, or 10 minute averaging/storage intervals.
 - Up to 21 weeks of sample/record time.
 - Memory storage of up to 21,500 data points that can be distributed into a maximum of 999 location files.
 - DustComm Pro Software supplied with RS-232 cable for downloading data to a PC.
 - Data translation to ASCII text files, importable into Excel or Lotus 1-2-3.
-

Security feature

Security access code of 1209 which prevents anyone from viewing, printing or downloading the data stored in the Haz-Dust IV.

Specifications

Introduction The Haz-Dust IV meets the following specifications.

SPECIFICATION	RANGE
Calibration	NIOSH 0600 with SAE Test Dust
Accuracy	+ 10%
Precision	0.02 mg/m ³
Sensing range	0.01 to 200 mg/m ³
Particle size range	0.1 to 10 µm Respirable 0.1 to 50 µm Thoracic 0.1 to 100 µm Inhalable (IOM)
Recording time	1 second, 1 minute and 10 minute averages
Flow rate	1.5 to 2.3 LPM
Memory	21,500 data points
Locations	Up to 999 storage locations
Output	RS-232
Operating temperature	32 to 120° F (0° -50°C)
Humidity range	95% non-condensing
Battery	Rechargeable NiCad
Battery life	8 hours
Charging time	8 hours
Size	9 x 3.5 x 2.5 in (22.9 x 8.9 x 6.4 cm)
Weight	3 lbs. (1.4 kg)

Components

Components

The following components ship with the Haz-Dust IV.

- Haz-Dust IV Monitor.
 - Battery charger.
 - Trimming tool.
 - Detachable Thoracic sampling inlet.
 - Opaque filter cassette holder.
 - Haz-Dust IV Multi Media CD-Rom Including: DustComm Pro Software and the Instruction Manual.
 - RS232 9-pin serial cable (female to male).
 - Zeroing filter.
 - Durable carrying case.
-

Chapter 2 - Operating Parameters of the Haz-Dust IV

Chapter 2

Operating Parameters of the Haz-Dust IV

Chapter Overview

Introduction This chapter describes the steps involved in starting the Haz-Dust IV and configuring its operating parameters.

In this chapter This chapter contains the following topics.

Topic	See Page
Turning the Haz-Dust IV on and off.	2-2
Using the Menu.	2-3
Setting the Alarm.	2-4
Setting the Date and Time.	2-5
Clearing the Memory.	2-6

Turning the Haz-Dust IV On and Off

Introduction

Power can be supplied to the Haz-Dust IV either from its internal battery or from an AC power source.

Note: **THE BATTERY MUST BE FULLY CHARGED** before each use. See page 5-8 for information on battery maintenance.

Power-On

Press the **ON/OFF** key to turn the Haz-Dust IV monitor on.

Result: The unit will turn on and the Title Screen will appear.

Note: Allow at least two minutes for the Haz-Dust IV to equilibrate and stabilize.

Power-Off

Press the **ON/OFF** key a second time to turn the Haz-Dust IV off.

Using the Menu

Introduction The Haz-Dust IV menu appears on the 4x20-character liquid crystal display (LCD).

Note: See Appendix A for menu option flow charts.

Accessing the main menu Press **ENTER** from the Title Screen to access the Main Menu.

Using the menu The Haz-Dust IV is operated using the following menu selections.

Selection	Function
<I/O>	Turns the Haz-Dust IV on and off.
<ENTER>	Activates the selected option.
< → >	Selection Arrow. Indicates the selected menu option. Located on the LCD Display.
< ↑ >	Scrolls the Selection Arrow up one line in a menu list.
< ↓ >	Scrolls the Selection Arrow down one line in a menu list.

```
  ** Haz-Dust IV **  
  Personal Real-Time  
  Particulate Monitor  
  E.D.C. Ver 1.0 5/05
```

Figure 2-2. The Title Screen of the Haz-Dust IV.

```
→  Run  
    Review Data  
    Special Functions  
    Auto Zero
```

Figure 2-3. The Main Menu of the Haz-Dust IV.

Setting the Alarm

Introduction An audible alarm can be set to alert the worker of approaching threshold limits.

Alarm settings The concentration level must be set to the defined agency standard for the particulate type being sampled.

Note: See Appendix B for a listing of the most common dust particulates and their corresponding concentration levels.

Using the alarm Follow the steps in the table below to set the alarm level.

Step	Action	
1	Select Special Functions from the Main Menu.	
2	Select Set Alarm .	
3	Enter the appropriate concentration level using the table below.	
	To...	Press...
	Increase the value of the selected digit.	< ↑ >
	Decrease the value of the selected digit.	< ↓ >
	Select the next digit.	ENTER
4	Press ENTER after the last digit is entered.	
	Result: The alarm has been set and the Main Menu appears.	

Setting the Date and Time

Introduction The date and time are pre-set by the factory to Eastern Standard Time and are maintained by an internal clock. It may be necessary to change the date and time due to local time zones or daylight savings time.

Note: It is important that the system date and time are correct for accurate record keeping.

Date and Time settings Time is entered and displayed in military time format.
Date is entered and displayed in European format (i.e., MON. 17-DEC-04).

View settings Follow the steps in the table below to check the units date and time.

Step	Action
1	Select Special Functions from the Main Menu.
2	Select Date/Time .
3	Select View Date/Time .
	Result: The unit's current date and time will display.
4	Press ENTER to return to the Date/Time Screen.

Change settings Follow the steps in the table below to change the units date and time.

Step	Action								
1	Select Special Functions from the Main Menu.								
2	Select Date/Time .								
3	Select Set Date/Time .								
4	Enter the correct date and time using the steps in the table below.								
	<table border="1"> <thead> <tr> <th>To...</th> <th>Press...</th> </tr> </thead> <tbody> <tr> <td>Increase the value of the selected digit.</td> <td>< ↑ ></td> </tr> <tr> <td>Decrease the value of the selected digit.</td> <td>< ↓ ></td> </tr> <tr> <td>Select the next digit or field.</td> <td>ENTER</td> </tr> </tbody> </table>	To...	Press...	Increase the value of the selected digit.	< ↑ >	Decrease the value of the selected digit.	< ↓ >	Select the next digit or field.	ENTER
To...	Press...								
Increase the value of the selected digit.	< ↑ >								
Decrease the value of the selected digit.	< ↓ >								
Select the next digit or field.	ENTER								
5	Press ENTER when the correct information has entered.								
	<table border="1"> <thead> <tr> <th>To...</th> <th>Select...</th> </tr> </thead> <tbody> <tr> <td>Update the selected date and time.</td> <td>Set Date/Time</td> </tr> <tr> <td>Return to the Date/Time screen without saving changes.</td> <td>Cancel</td> </tr> </tbody> </table>	To...	Select...	Update the selected date and time.	Set Date/Time	Return to the Date/Time screen without saving changes.	Cancel		
To...	Select...								
Update the selected date and time.	Set Date/Time								
Return to the Date/Time screen without saving changes.	Cancel								

Clearing the Memory

Introduction

The memory of the Haz-Dust IV can be cleared at any time.

Note: All data points in all locations will be deleted from memory.

Clearing memory

Follow the steps in the table below to clear the memory of the Haz-Dust IV.

Step	Action
1	Select Special Functions from the Main Menu.
2	Select System Options .
3	Select Erase Memory .
4	Select Yes to clear memory. Note: Selecting No will cancel the process without clearing memory.

Chapter 3 - Operating the Haz-Dust IV

Chapter 3

Operating the Haz-Dust IV

Chapter Overview

Introduction This chapter describes and diagrams operation procedures of the Haz-Dust IV.

In this chapter This chapter contains the following topics.

Topic	See Page
Selecting the Particle Size:	3-2
Thoracic Dust Particulates	3-3
Respirable Dust Particulates	3-4
Inhalable Dust Particulates	3-5
Auto-Zero	3-7
Sampling	3-10
Location Codes	3-13
Reviewing Stored Data	3-14
Statistics Menu Tree	3-16

Selecting The Particle Size

Introduction The inlet system of the Haz-Dust IV can be configured to sample Thoracic, Respirable, or Inhalable dust particulates. The following pages detail the selection process for each of these particle types.

Inlets The table below lists the particulate type, agency standard, and required inlets.

Particulate	Standards	Required Inlet	Diagram Detail
Thoracic	EPA PM-10 & IP-10	Thoracic Sampling Inlet	A
Respirable	NIOSH 0600	SKC Respirable Dust 25mm Cyclone Inlet	B
Inhalable	NIOSH 0500	SKC IOM Sampling Adapter Inlet	C

Note: Inhalable particulate samples require the IOM inlet (detail C) to be inserted into the Thoracic sampling inlet.

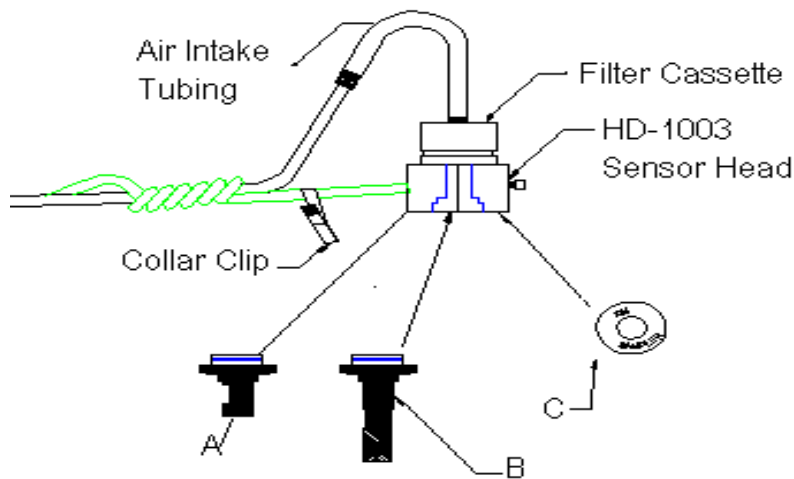

Figure 3-1. Diagram of sampling inlets for Thoracic (A), Respirable (B) and Inhalable (C) dust particles.

Thoracic Dust Particulates

Thoracic

Follow the steps in the table below to select Thoracic dust particulates.

Step	Action
1	Select Special Functions from the Main Menu.
2	Select System Options .
3	Select Extended Options .
4	Select Size Select, then Select .
5	Select Thoracic .
	<u>Result:</u> The Main Menu is displayed.
6	Thread the Thoracic sampling inlet into Haz-Dust IV sensor. Note: The sampling inlet contains plastic threads be careful not to cross threads. To insert and remove the sampling inlet it must be screwed in and out. NOTE: Sensor must be removed from lapel bracket prior to installation. Note: If also collecting concurrent 37mm filter samples place a clean gravimetric filter in the filter cassette. The flow rate should be checked each time a new gravimetric filter is used. See page 5-5 for information on checking the flow rate.
7	Attach the filter cassette to the sensor head of the Haz-Dust IV.
8	Attach the air intake tubing to the filter cassette.
9	Turn to page 3-7 and follow the instructions to Auto-Zero the Haz-Dust IV.

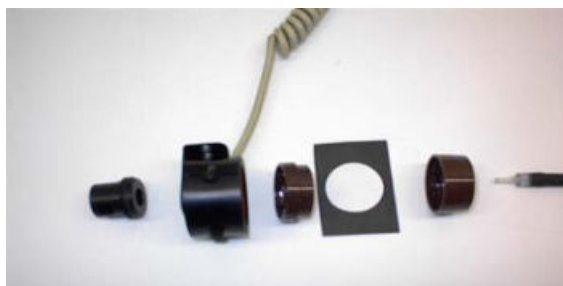

Figure 3.2a

Figure 3-2 and 3-2a. Thoracic Inlet, sensor head, disassembled filter cassette, 37 mm filter, and air intake tubing. Optical sensor mounted on lapel bracket.

Respirable Dust Particulates

Respirable

Follow the steps in the table below to select Respirable dust particulates.

Step	Action
1	Select Special Functions from the Main Menu.
2	Select System Options .
3	Select Extended Options .
4	Select Size Select, then Select .
5	Select Respirable . Result: The Main Menu is displayed.
6	Screw in GS cyclone adapter p/n GSA-202 into bottom of sensor. Insert the GS-Cyclone into the GSA-202. NOTE: The sensor lapel bracket will have to be removed to install the GSA-202 and GS Cyclone. Note: If also collecting concurrent 37mm filter samples place a clean gravimetric filter in the filter cassette. The Flow Rate should be checked each time a new gravimetric filter is used. See page 5-5 for information on checking the flow rate.
7	Attach the filter cassette to the sensor of the Haz-Dust IV.
8	Attach the air intake tubing to the filter cassette.
9	Turn to page 3-7 and follow the instructions to Auto-Zero the Haz-Dust IV.



Figure 3.3. Component identifications from left to right: SKC GS-Cyclone for Respirable sampling, GSA-202 adapter, sensor head, disassembled filter cassette, filter, and air intake tubing.

***Requires the GSA-202 Cyclone adapter to fit.**

Inhalable Dust Particulates

Inhalable

When using the Haz-Dust IV monitor for Inhalable sampling a suitable entry must be used.

The SKC IOM Adapter is designed to allow the use of the front half of an IOM cassette and lock ring as an Inhalable entry to the Haz-Dust IV sensing chamber.

Selecting Inhalable

Follow the steps in the table below to select Inhalable dust particulates.

Step	Action
1	Select Special Functions from the Main Menu.
2	Select System Options .
3	Select Extended Options .
4	Select Size Select, Then Select .
5	Select Inhalable . Result: The Main Menu is displayed.
6	Assemble the IOM & IA-202 as configured in diagram 3.4 & illustration 3.5. Note: If also collecting concurrent 37mm filter samples place a clean gravimetric filter in the filter cassette. The Flow Rate should be checked each time a new gravimetric filter is used. See page 5-5 for information on checking the flow rate.

SKC IOM components used consists of IOM front plate, cassette front and cassette grid. IA-202 accessories consist of rubber washer, ring filter and end cover adapter.

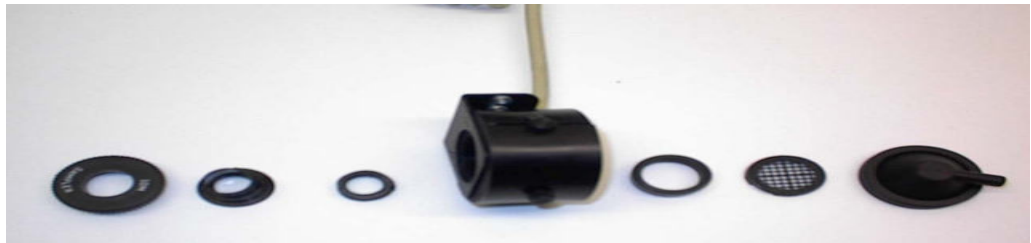

Figure 3-4. IOM component identification layout from left to right. IOM front plate, cassette front, rubber washer, sensor head, filter ring, cassette grid and end cover adapter.

Continued on next page

Inhalable Dust Particulates, Continued

7	Follow the steps in the table below to prepare the IOM sampling adapter for use with the Haz-Dust IV.	
	Step	Action
	1	Insert rubber washer into IOM cassette front. Place into sensor and screw the IOM front plate over it into the sensor.
	2	Attach the cassette grid to the filter ring.
	3	Push end cover over cassette grid and filter ring. See figure 3.5 for visual aid.
8	Attach the air intake tubing to the end cover.	
9	Turn to page 3-7 and follow the instructions to Auto-Zero the Haz-Dust IV.	

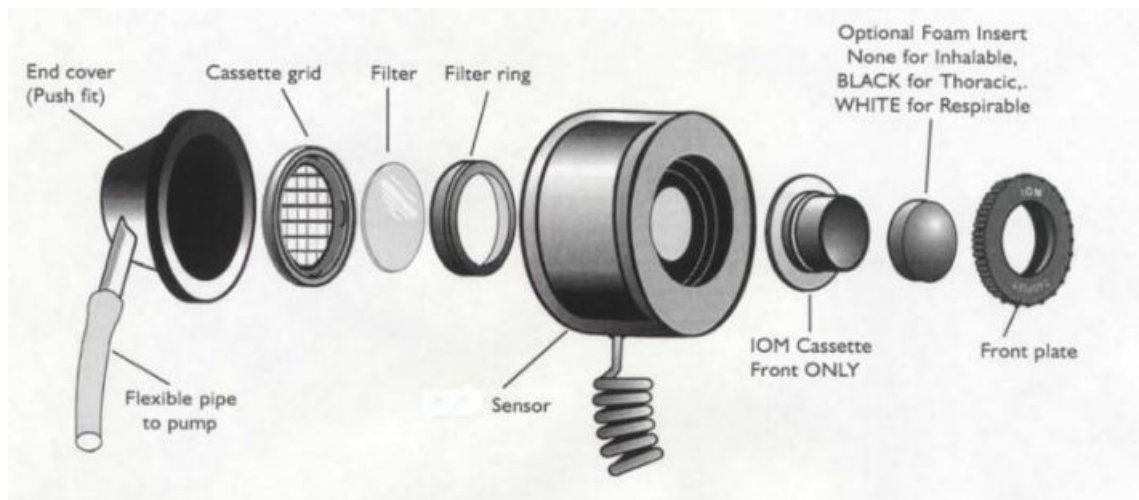

Figure 3-5. Disassembled IOM Sampling Adapter. SKC catalog number 225-70.

Auto-Zero

Introduction Auto-Zero sets the measurement baseline of the Haz-Dust IV to zero mg/m³. The Auto-Zero check should take place prior to beginning a new set of measurements.

Auto-Zero Follow the steps in the table below to Auto-Zero the Haz-Dust IV.

Note: The battery should be fully charged before beginning the Auto-Zero process.

Step	Action								
1	Be sure the appropriate sampling inlet is attached to the sensor head of the Haz-Dust IV using the table below.								
	<table border="1"> <thead> <tr> <th>If sampling...</th> <th>Then insert the...</th> </tr> </thead> <tbody> <tr> <td>Thoracic Particulates</td> <td>Thoracic sampling inlet</td> </tr> <tr> <td>Inhalable Particulate</td> <td>SKC IOM and IA-202 sampling inlet</td> </tr> <tr> <td>Respirable Particulates</td> <td>SKC GS Cyclone and GSA-202 sampling inlet</td> </tr> </tbody> </table>	If sampling...	Then insert the...	Thoracic Particulates	Thoracic sampling inlet	Inhalable Particulate	SKC IOM and IA-202 sampling inlet	Respirable Particulates	SKC GS Cyclone and GSA-202 sampling inlet
If sampling...	Then insert the...								
Thoracic Particulates	Thoracic sampling inlet								
Inhalable Particulate	SKC IOM and IA-202 sampling inlet								
Respirable Particulates	SKC GS Cyclone and GSA-202 sampling inlet								

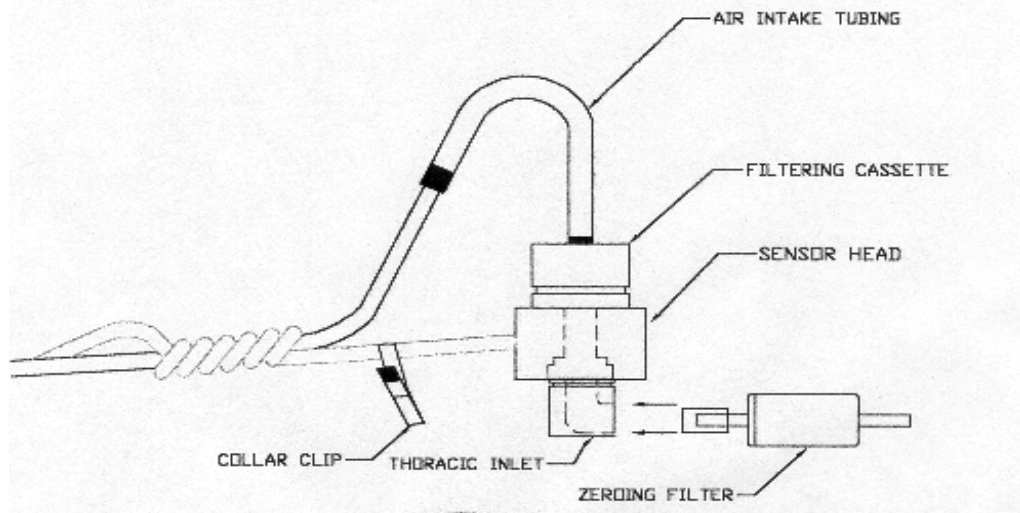

Figure 3-6. Diagram of zeroing filter being inserted into the Thoracic sampling inlet. This procedure is used for both Thoracic and Inhalable dust particles.

Continued on next page

Auto-Zero, Continued

2	Insert the Zeroing Filter using the table below.	
	If Sampling...	Then...
	Thoracic Particulates (Figure 3.7a)	Insert the zeroing filter into the Thoracic sampling inlet.
	Inhalable Particulates (Figure 3.7b)	Insert the zeroing filter (p/n ZA-202A) into the front of the IOM front plate refers to figure 3.7b.
	Respirable Particulates (Figure 3.7c)	Insert the zeroing filter into the bottom of the GSA-202. GS-Cyclone adapter.

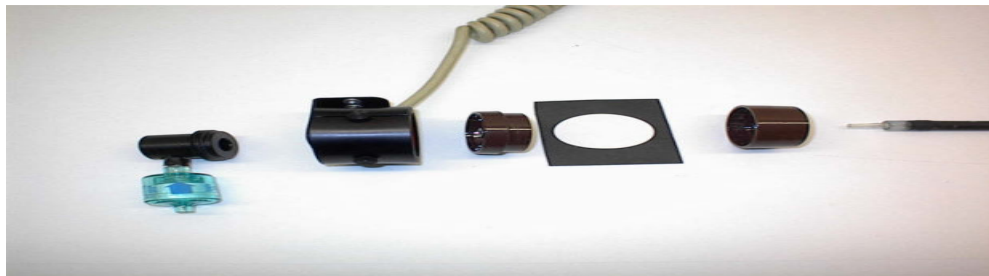

Figure 3.7a Zeroing filter (p/n ZF-102) being attached to the Thoracic sampling inlet.



Figure 3.7b. Zeroing filter (p/n ZA-202A) being attached to the Inhalable sampling inlet.

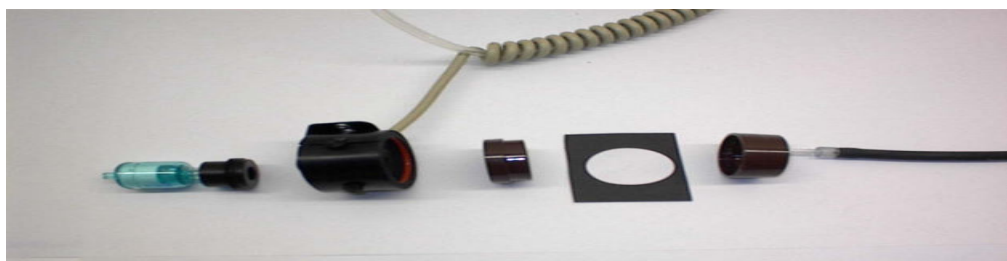

Figure 3.7c. Zeroing filter (p/n ZF-102) being attached to GSAS-202 GS-Cyclone adapter.

Continued on next page

Auto-Zero, Continued

3	Select Auto Zero from the Main Menu.
4	Select Auto-Zero . <u>Result:</u> The Auto-Zeroing screen appears briefly. <u>Note:</u> Wait 50 Seconds. The unit automatically executes the steps necessary to reestablish the baseline. <u>Result:</u> The Main Menu is displayed when the auto-zero process is complete.
5	Remove the zeroing filter and begin the sampling process described on page 3-10.

Sampling

Introduction Once you have selected a Particle Size and completed the Auto-Zero process the Haz-Dust IV is ready to begin sampling.

Conditions The following conditions must be met before starting the sampling process.

Condition...	For further Information See Page...
The correct particle size must be selected.	3-2
The correct sampling inlet must be attached.	3-2
The correct date and time must be set.	2-5
The Auto-Zero process must be complete.	3-7
The alarm level must be set if sampling with the alarm feature.	2-4

Sampling Follow the steps in the table below to begin dust sampling.

Step	Action									
1	Select Sample Rate from the Special Functions Menu.									
2	Select a sample interval using the table below.									
	<table border="1"> <thead> <tr> <th>Select...</th> <th>For maximum sampling time of...</th> </tr> </thead> <tbody> <tr> <td>1 Second</td> <td>6 Hours</td> </tr> <tr> <td>2 Seconds</td> <td>12 Hours</td> </tr> <tr> <td>10 Seconds</td> <td>60 Hours</td> </tr> </tbody> </table>	Select...	For maximum sampling time of...	1 Second	6 Hours	2 Seconds	12 Hours	10 Seconds	60 Hours	<p>Note: A sample is taken each second and averaged by the sample interval time selected.</p>
Select...	For maximum sampling time of...									
1 Second	6 Hours									
2 Seconds	12 Hours									
10 Seconds	60 Hours									
3	Choose the memory storage type using the table below.									
	<table border="1"> <thead> <tr> <th>To...</th> <th>Select...</th> </tr> </thead> <tbody> <tr> <td>Erase all previously recorded data points in all locations.</td> <td> Overwrite, then Select Yes to confirm, Note: Selecting No will cancel sampling process without effecting memory. </td> </tr> <tr> <td>Add data points to the next consecutive location.</td> <td>Continuation.</td> </tr> </tbody> </table>	To...	Select...	Erase all previously recorded data points in all locations.	Overwrite, then Select Yes to confirm, Note: Selecting No will cancel sampling process without effecting memory.	Add data points to the next consecutive location.	Continuation.	<p>Note: See page 3-13 for explanation of location codes.</p>		
To...	Select...									
Erase all previously recorded data points in all locations.	Overwrite, then Select Yes to confirm, Note: Selecting No will cancel sampling process without effecting memory.									
Add data points to the next consecutive location.	Continuation.									

Continued on next page

Sampling, Continued

4	Choose the security level using the table below.	
	To...	Select...
	Use the security feature	Yes
	Bypass the Security feature	No , then, go to step 6.
5	Enter the Security Code of 1209 using the table below.	
	To...	Press...
	Increase the value of the selected digit	< ↑ >
	Decrease the value of the selected digit	< ↓ >
	Select the next digit	ENTER
	Result: When all digits have been entered the LCD will display the Sample Record Menu.	
6	Attach the belt clip to belt of the worker.	
7	Clip the sensor onto the worker's collar within the OSHA defined breathing zone.	
8	Sample and record the data using the table below.	
	To Sample...	Select...
	Without the alarm feature	Run
	With the alarm feature	Sample/Rec-ALM
	Results:	
	<ul style="list-style-type: none"> • The internal pump is activated and the sampling process begins. • The Data Record Screen is displayed (figure 3.10). 	
	Note: Maximum sampling time is based on the sampling interval selected in step number two.	



Figure 3.9. Detachable sensor head attached to workers collar.

Continued on next page

Sampling, Continued

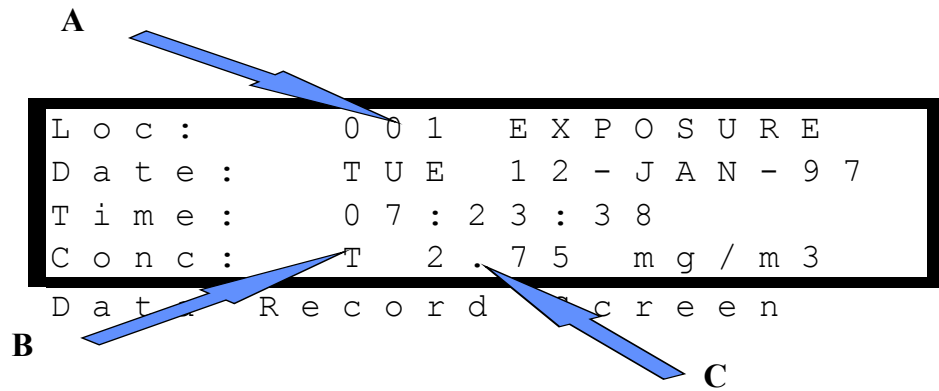

Figure 3.10. The Data Record Screen. The table below describes the diagram details.

Detail	Explanation
A	Indicates Location Code of data being sampled. A record should be kept of the site that corresponds to each location code. Note: See page 3-13 for explanation of location codes.
B	Particulate type being sampled. T = Thoracic R = Respirable I = Inhalable
C	Concentration. A negative number may indicate the baseline of the unit is not set to zero and the Auto-Zero process should be performed (page 3-7).

Ending the Sampling process

Press **ENTER** to stop data collection and return to the Main Menu.

Note: If the security feature was used during sampling a confirmation screen will require the security code of 1209 to be entered.

Custom Correction Factor on HD-1004

Before a SCALE factor can be entered, a gravimetric result must be obtained from the filter contained behind the sensing head. The filter must be preweighed.

Step 1:

Go to Special Functions option by pressing either the down button or the up button until the arrow is opposite Special Functions. Press **ENTER** button.

```
Run
Review Data
→ Special Functions
Auto-Zero
```

Step 2:

Scroll arrow to System Options option and press the **ENTER** button.

```
→ System Options
Date/Time
Set Alarm
Cancel
```

Step 3:

Scroll arrow to Extended Options and press **ENTER** button.

```
→ Extended Options
Sample Rate
Erase Memory
Cancel
```

Step 4:

Scroll arrow to Size Select Option and press **ENTER** button.

```
→ Size Select
Battery Status
Cancel
```

Step 5:

Scroll arrow to Apply Scale Option and press **ENTER** button.

```
→ Select
Apply Scale
Restore Default
Cancel
```

Step 6:

Scroll arrow to Respirable, Thoracic, or Inhalable Option and press **ENTER**. The fraction selected depends on the fraction you have sampled and obtained a gravimetric result for. **NOTE:** To do this for respirable you must have a gravimetric result, obtained by using the IOM with foam and filter.

```
→ Respirable
Thoracic
Inhalable
```

Step 7:

Default scale of 01.00 will be seen. Enter the SCALE factor required by using the **UP**, **DOWN** and **ENTER** buttons. The screen will now return to the **APPLY SCALE** screen.

```
* SCALE *

Scale: 01.00
```

How to Calculate the SCALE Factor:

The TWA result obtained from the filter used during a monitoring exercise is compared against the TWA displayed by the HD-1004 LCD in the **REVIEW DATA** option.

From the two results a simple calculation is used to obtain the SCALE factor for that sample and atmosphere type.

Filter TWA result = SCALE
HD-1004 TWA result

EXAMPLE:

Filter TWA was 5 mg/m³
HD-1004 TWA was 2.5 mg/m³

$$\frac{5}{2.5} = 2$$

Scale factor to be entered for the next sample in the same atmosphere is 02.00

Location Codes

Introduction The Haz-Dust IV assigns a location code to each sampling sequence. The active location is indicated in the Data Record Screen (figure 3.10).

Maximum location codes The Haz-Dust III can store a total of 21,500 data points, which can be distributed into a maximum of 999 locations.

Assigning location codes The location code assigned to the site is determined by the memory storage type selected in step number three of the sampling process (page 3-10).

Use the table below to identify the location code being used.

Data storage type selected...	The Haz-Dust IV Assigns...
Continuation	The Next Consecutive Value as the Location Code. Example: If data was previously stored in locations #001 and #002 the data being collected will be stored in location #003.
Overwrite	001 as the Location Code and all previously stored data points in all locations are erased.

Reviewing Stored Data

Introduction The Haz-Dust IV provides extensive capabilities for reviewing internally stored data and statistics on the LCD.

LCD display The following information is displayed on the LCD.

Display	Description
Date	Date of sampling.
Start	Time sampling began.
Stop	Time sampling was terminated.
Time	Time of occurrence of reported statistic.
MAXIMUM Sample	Highest concentration of dust particles.
MINIMUM Sample	Lowest concentration of dust particles.
T.W.A.	Time weighted average concentration of dust particles.
Elapsed	Elapsed time of the time weighted average.
S.T.E.L.	Short-term exposure limit.

Viewing data on the LCD Follow the steps in the table below to review stored information and statistics. Review the flow chart on page 3-16.

Step	Action	
1	Select Review Data .	
2	Select Statistics .	
3	Determine your next step using the table below.	
	If...	Then the...
	Memory holds data points in other locations.	Review Location Screen appears.
	Memory has been cleared of all data points.	The Scanning Memory Screen displays. Go to step 7.
4	Select the Location using the table below.	
	To review...	Select...
	The Location displayed in the Review Loc field.	Review Loc XXX and go to step 7.
	A different Location	New Location and continue to step 5.

Continued on next page

Reviewing Stored Data, Continued

5	Enter the desired Location in the Location Select Screen using the table below (figure 3-11).	
	To...	Press...
	Increase the value of the selected digit.	< ↑ >
	Decrease the value of the selected digit.	< ↓ >
	Select the next digit or field.	ENTER
6	Press ENTER when the desired location code has been entered. Result: The Scanning Memory Screen displays. If the location is being reviewed for the first time scrolling dots will appear indicating the microprocessor is computing data.	
7	The first of five statistics screen appears when data is computed. Scroll through the statistics screens using the table below.	
	Press...	To Scroll...
	< ↓ >	Forward through the statistic screens.
	< ↑ >	Backward through the statistic screens.

**** Location Select ****

Range: 001 thru 002

Loc: 002

Figure 3-11. Location Select Screen. Range: indicates number of location files stored in memory. Loc: indicates location code being reviewed.

Chapter 4 – DustComm Pro V.1.2

Introduction to the DustComm Software

Introduction

DustComm is a powerful and flexible Windows application software package designed for use with the Haz-Dust Particulate Monitoring Equipment.

DustComm is both communications software that enables stored project data to be downloaded to a PC, and a data manipulation tool, enabling detailed analysis and reporting of sampled data.

Spreadsheet applications

DustComm easily translates data into spreadsheet ASCII text files. These files can be open into spreadsheet programs such as Microsoft Excel

Data plots

The data plots provided with DustComm enable:

- Detailed statistical analysis.
 - The creation of graphics and charts.
 - The mathematical correction of particle characteristics when aerosol significantly differs from calibration dust.
-

Installing DustComm

Introduction DustComm installation is easy and quick, the entire process should take less than 5 minutes.

Minimum system requirements Windows ME or Higher.
4 MB available disk space.
8 MB RAM.

Software installation Follow the steps in the table below to install DustComm.

Note: It is assumed that the CD-Rom Drive is the “D” Drive. Substitute D with the appropriate drive letter if necessary.

Step	Action
1	Start Windows.
2	Close all open applications.
3	Insert <i>Installation Disk</i> into the D drive.
4	Open My Computer
5	Select the folder named “DustComm V1.2” and double click to enter.
6	Select the icon named “Setup” and double click. See Figure1.
7	Follow the installation wizard steps.



Figure 1: DustComm Software Folder with “Setup” Selected in Windows XP.

Loading the DustComm Software

Windows ME Follow the steps in the table below to load the DustComm software if using Windows ME.

Step	Action
1	Select the Start Menu.
2	Select Programs.
3	Select the folder EDC DustComm Pro 1.2
4	Select DustComm Pro 1.2

Windows NT, 2000 & XP Follow the steps in the table below to load the DustComm Software if using Windows NT, 2000 & XP.

Step	Action
1	Double Click on the icon on your desktop. NOTE: If shortcut icon does not appear on desktop follow the steps for Windows ME.

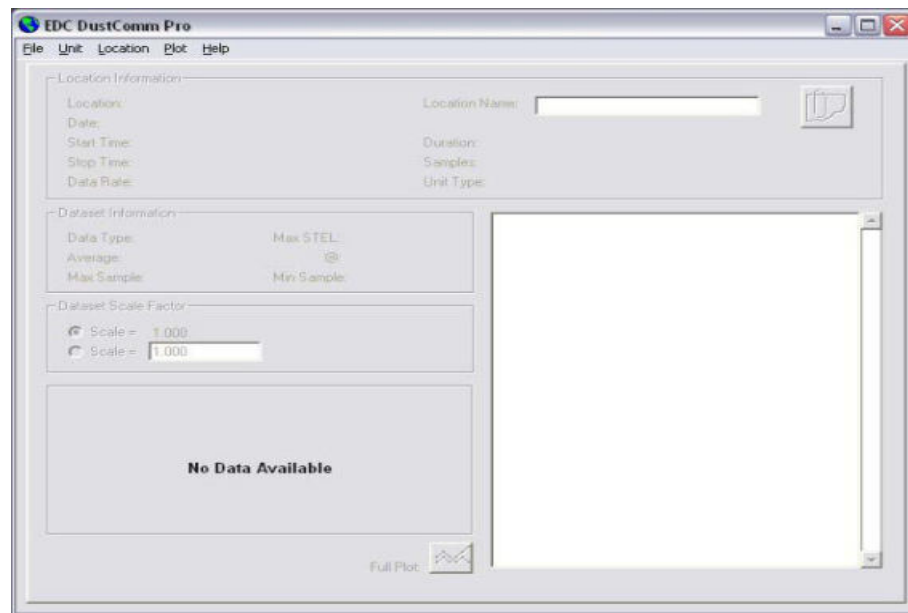

Figure 2. DustComm Screen immediately after loading software.

Menu Selections

Introduction

Figures 3 through 5 show each of the DustComm menu options.

Note: If a menu option is displayed in light type it is not available during the current task.

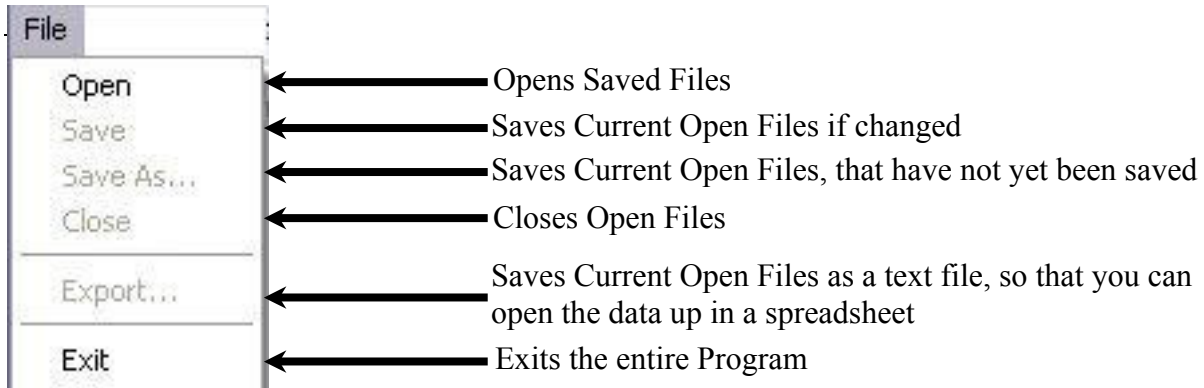

Figure 3. File Menu Options.

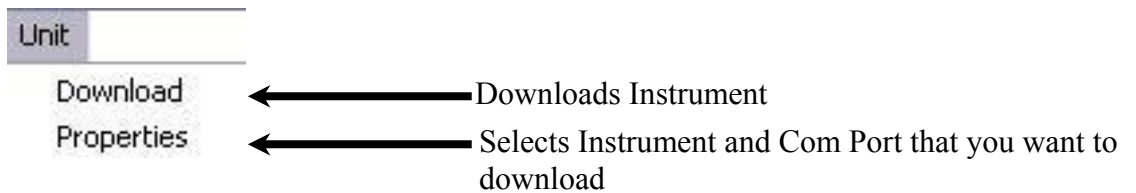

Figure 4. Unit Menu Options.

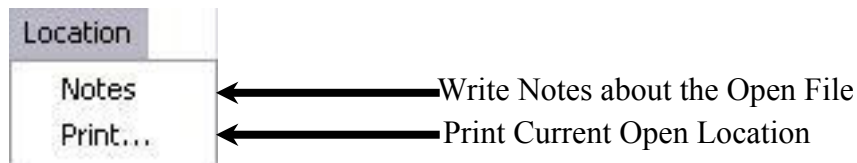

Figure 5. Location Menu Options.

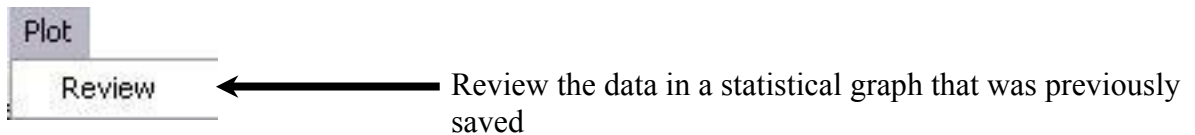

Figure 6. Plot Menu Options.

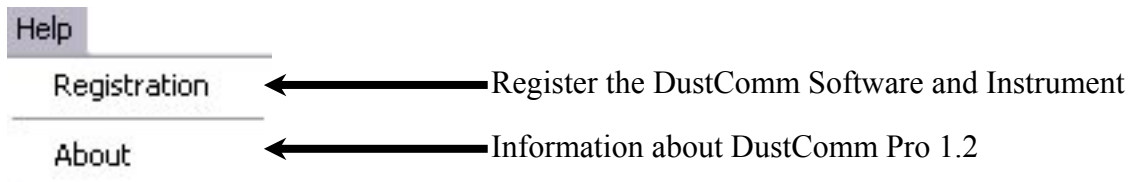

Figure 7. Help Menu Options.

File Menu Commands

Introduction Use the File Menu option to open, save, print, close and export sampled data. You can also use the File Menu to Exit the DustComm Pro Software

Notes:

- Data is sorted by time collected.
 - Data points are reported in mg/m³.
-

Opening an existing project folder

Follow the steps in the table below to retrieve stored project data.

NOTE: A sample .dcm file is preloaded for review of software options.

Step	Action
1	Select File .
2	Select Open .
3	Double click on the desired Project Folder. Note: DustComm will save all files in My Documents, or user selected folder.

Saving a project folder

Follow the steps in the table below to store project data.

Step	Action	
1	Select File .	
2	If... <ul style="list-style-type: none"> • Saving the data in the project folder for the first time, or, • Saving an existing folder to a new name or location. 	Then Select... <ol style="list-style-type: none"> 1. Save As, then, 2. Type a file name for the project file. 3. Select OK.
	Saving an updated version of an existing project folder to the same file name and location.	Save
Result: The data is saved in the new project folder and the new file name is displayed in the title bar. Only with Save As with the data have a new file name and location if selected.		

Continued on next page

File Menu Commands, Continued

Exit software Exit Communication Software in one of two ways.

Option number	Action
1	1. Select File . 2. Select Exit .
	Or
2	Single click on the “X” in the upper right hand corner of the screen.

Downloading Data

Introduction Internally stored data can be downloaded to DustComm for detailed analysis.

Downloading data The three major steps used to download data from the EDC dust-monitoring unit to a PC are listed below and detailed in the next few pages.

1. Connect the cable.
 2. Prepare the PC for data transmission.
 3. Prepare the EDC dust-monitoring unit for data transmission.
-

Connect the cable Follow the steps in the table below to connect the cable for data transmission.

Step	Action
1	Connect one end of the supplied RS232 cable to the EDC dust-monitoring unit. Note: If USB compatibility needed you will need to purchase a serial to USB adapter.
2	Connect the other end of the RS232 cable to the appropriate COMM port on the PC. Note: Check that both connections are secure. An intermittent connection can disrupt data transmission.

Preparing the PC Follow the steps in the table below to prepare the PC for data transmission.

Note: Multiple locations will be separated by tabs at the bottom of the program.

Step	Action
1	Open DustComm.
2	Select Unit and Select Properties .
3	Under the Properties selection choose your unit and the Com Port that you want to connect. Press Ok when you are finished
4	Select Unit and Select Download .
5	When the items above are finished you should see the download box appear.

Continued on next page

Downloading Data, Continued

Preparing the unit.

Follow the steps in the table below to prepare the EDC unit for data transmission.

Step	Action
1	Select Playback or Review Data (depending on your instrument) from the Main Menu on the unit.
2	Select Download .
3	Select To Dust Data Collector .
4	Press ENTER . Result: The Transmitting window appears. Note: Bars on the PC screen should increase as the unit downloads.
5	When the transmission is complete... <ul style="list-style-type: none"> • The To Dust Data Collector selection screen is displayed on the units monitor. The unit may be shut off at this time. • The downloaded data is displayed in the Project Folder on the PC. (Figure 8).

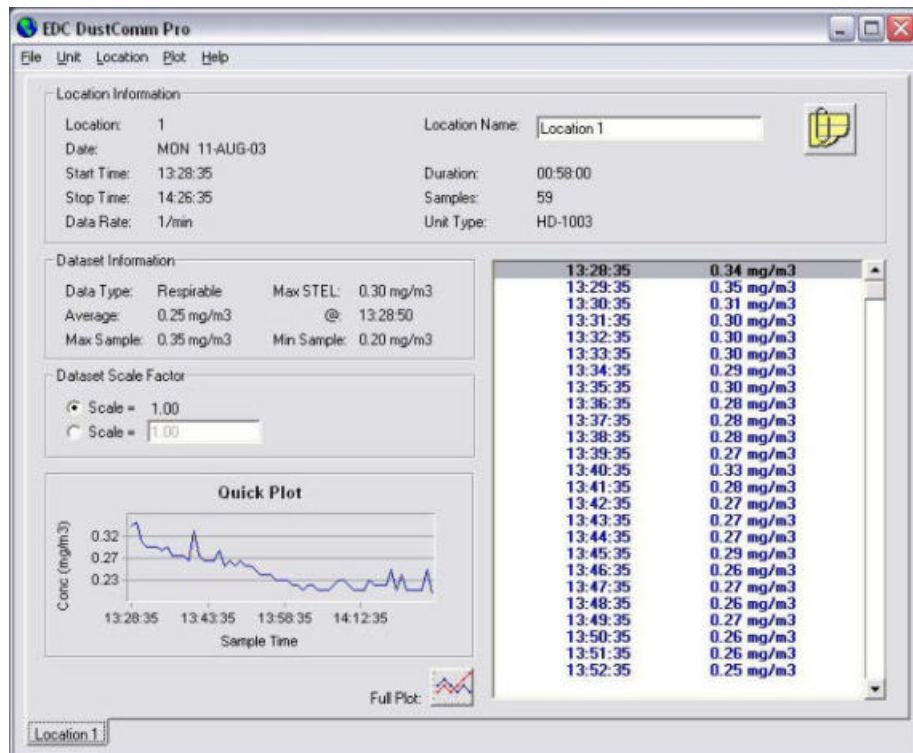

Figure 8. Project File after data has been transmitted.

DustComm Pro Window

Introduction Each section of the DustComm Pro Window will explain a different part of the statistics.

Location Information	The Location information will give you general details about the downloading statistics. Such as date, time, start/stop time, data rate, duration, how many samples were downloaded and the unit. There is also box so that you can name the location and a shortcut to type in any notes you would like to add.
-----------------------------	--

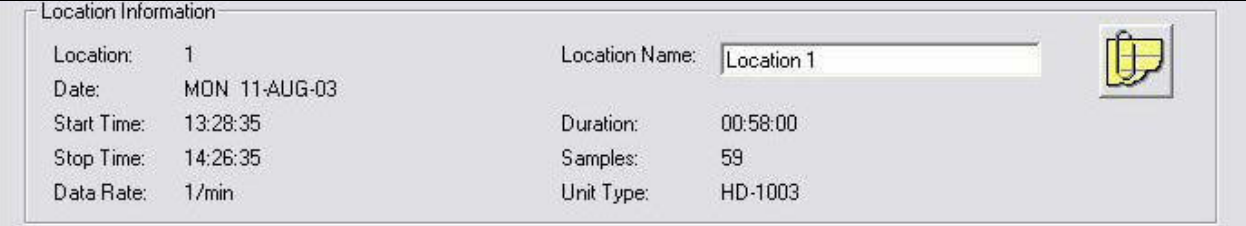

Figure 9. Location Information section of the DustComm Pro Window.

Dataset Information	The Dataset Information will tell you more specific information about the downloaded statistics. Such as type of data, the average, the Max/Min Sample and the Max STEL.
----------------------------	--



Figure 10. Dataset Information section of the DustComm Pro Window.

Continued on the next page

DustComm Pro Window, Continued

Dataset Scale Factor	The dataset scale factor section of the DustComm Pro Window, is so that you can adjust the scale to be equal to your specific type of dust. You can read more about adjusting the scale factor on page15.
-----------------------------	---

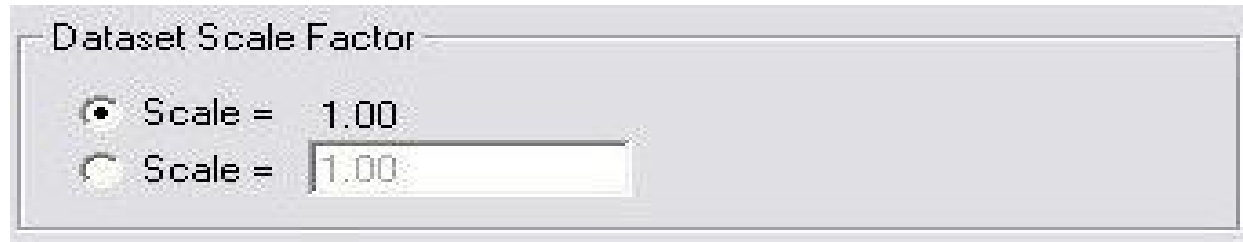

Figure 11. Dataset scale factor section of the DustComm Pro Window.

Quick Plot	The Quick Plot graph shows you a miniature version of the Full Plot. The Full Plot button is located directly below Quick Plot can you can read more about Full Plot on pages11-14.
-------------------	---



Figure 12. Quick Plot & Full Plot Button on the DustComm Pro Window.

DustComm Pro Window, Continued

Location Data	The location data section shows you the milligrams per cubic meter you sampled for and the times that they were sampled at.
----------------------	---

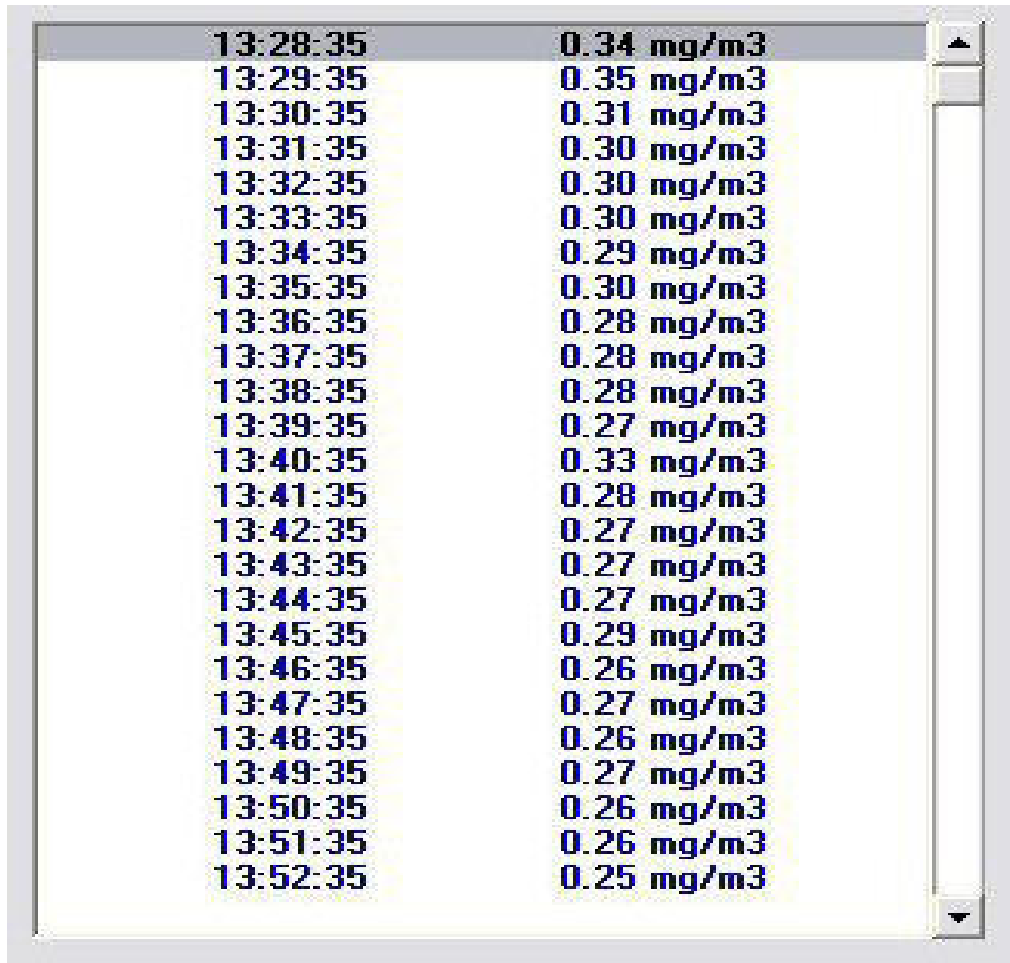

13:28:35	0.34 mg/m3
13:29:35	0.35 mg/m3
13:30:35	0.31 mg/m3
13:31:35	0.30 mg/m3
13:32:35	0.30 mg/m3
13:33:35	0.30 mg/m3
13:34:35	0.29 mg/m3
13:35:35	0.30 mg/m3
13:36:35	0.28 mg/m3
13:37:35	0.28 mg/m3
13:38:35	0.28 mg/m3
13:39:35	0.27 mg/m3
13:40:35	0.33 mg/m3
13:41:35	0.28 mg/m3
13:42:35	0.27 mg/m3
13:43:35	0.27 mg/m3
13:44:35	0.27 mg/m3
13:45:35	0.29 mg/m3
13:46:35	0.26 mg/m3
13:47:35	0.27 mg/m3
13:48:35	0.26 mg/m3
13:49:35	0.27 mg/m3
13:50:35	0.26 mg/m3
13:51:35	0.26 mg/m3
13:52:35	0.25 mg/m3

Figure 13. Location Data on the DustComm Pro Window.

Translating Data to an ASCII Text File

Introduction

Project Data must be translated into ASCII text format before it can be read by a spreadsheet application.

Translating data

Follow the steps in the table below to Translate Project Data into ASCII Text format.

Note: A Project Folder must be open to access the translate feature.

Step	Action
1	Select File from the Main Menu.
2	Select Export.
3	An “Export Locations” Window will appear. Select either All for all locations or select the range of locations you would like to export. Click OK when you have selected your locations.
4	An “Export To...” Window will appear. Type in the name that you would like to call your exported data and click Save .
6	When you are ready to open the data in a spreadsheet application. Open the spreadsheet program go to the Open menu, select all files under type of file name and double click on the file you want to review. This will result in your saved data opening in your spreadsheet program.

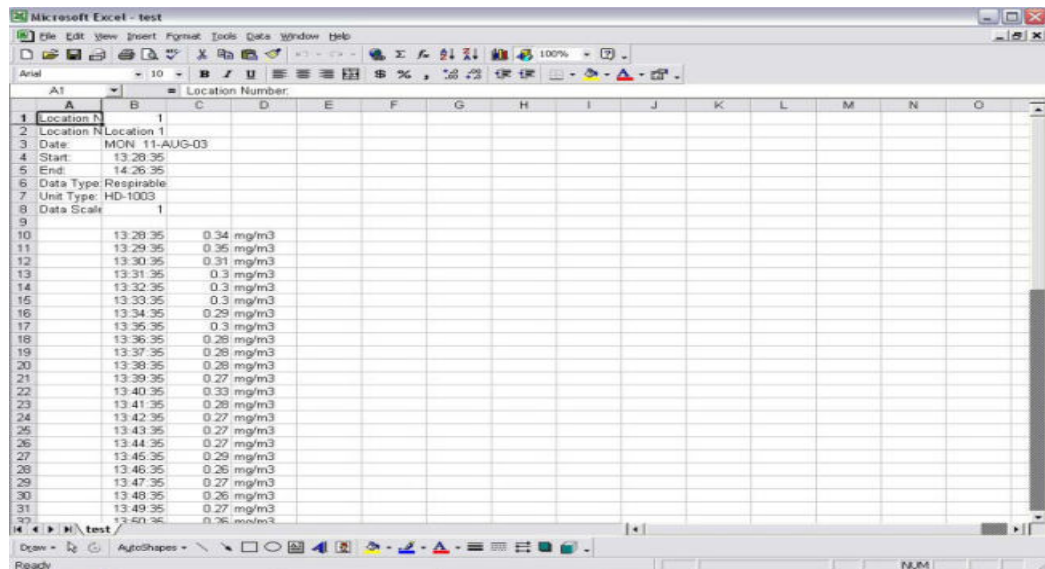

Figure 14. Exported Excel information.

Generating a Plot

Introduction A graph can be plotted with full plot located at the bottom of the DustComm Pro Window.

Generating a graph Follow the steps in the table below to generate a graph using the DustComm Plot menu selections.

Step	Action
1	Select Plot .
2	Select Review . This option is for graphs that have already been saved. Note: For new statistics click on the “Full Plot” Icon on the DustComm Pro Window.
3	The result is graph will be plotted to the screen (see figure 15 below).

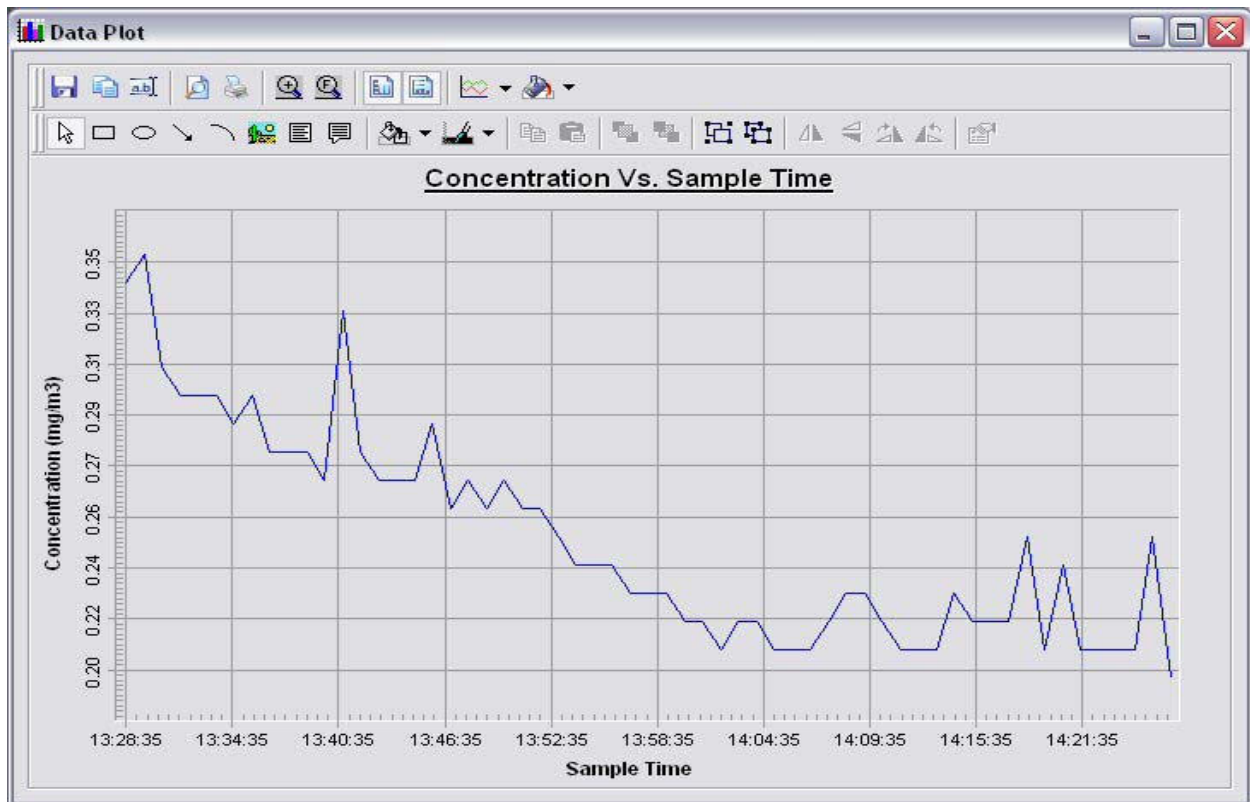

Continued on next page

Data Plot Menu Selections

Introduction At the top of the data plot will be a button bar. Below is an explanation of what each button does.

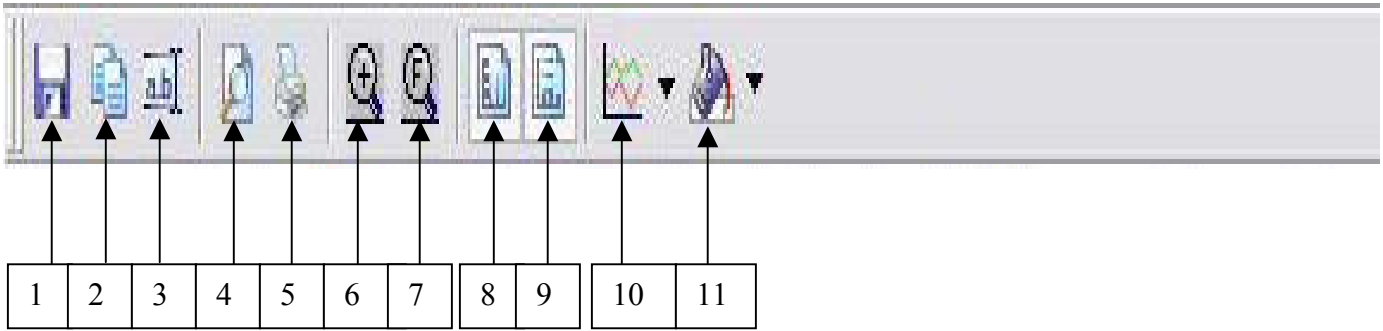

Number	Function
1	Saves plotted information as a DustComm Pro Chart (*.dcc).
2	Copies plot to a bitmap file.
3	Edits the title of the plot.
4	Page Setup Properties.
5	Prints the current plot.
6	Zooms into plot. By Highlighting from point to point that you want zoomed in on.
7	Returns to full screen of plot.
8	Adds or removes vertical lines.
9	Adds or removes horizontal lines.
10	Select the specific type of graph, i.e. bar or line graphs.
11	Changes color of the graph.

Data Plot Menu Selections, Continued

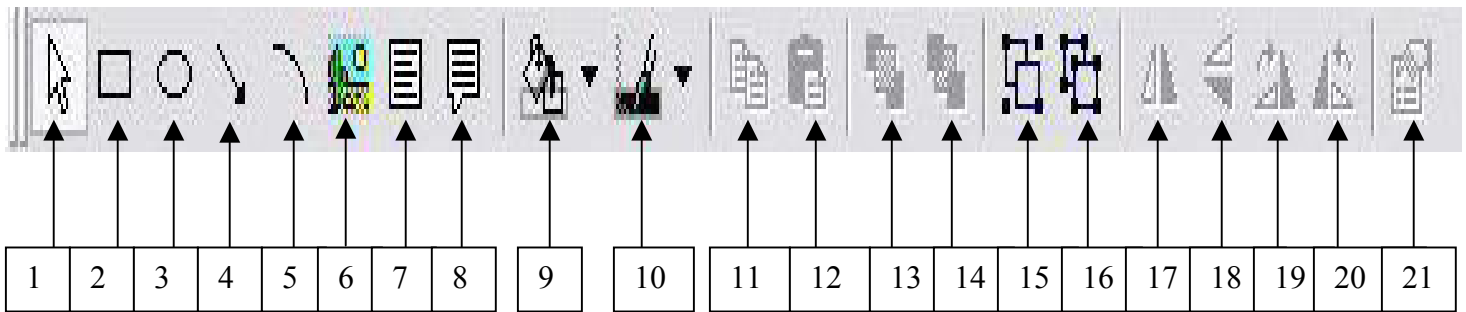

<i>Number</i>	<i>Function</i>
1	Pointer tool.
2	Insert Squares.
3	Insert Ovals.
4	Insert arrows.
5	Insert arched lines.
6	Insert a picture. Choose the size of your picture and then right click on the box and select properties. Select the picture tab and select picture. The picture you chose will appear in the box.
7	Insert a text box.
8	Insert a callouts with text.
9	Change the color of your squares, ovals, text boxes and callouts.
10	Change the color of the text in your text boxes and callouts.
11	Copy squares, ovals, text boxes and callouts.
12	Paste squares, ovals, text boxes and callouts.
13	Bring squares, ovals, text boxes and callouts to front.
14	Send squares, ovals, text boxes and callouts to the back.
15	Group squares, ovals, text boxes and callouts.
16	Ungroup squares, ovals, text boxes and callouts.
17	Flip over left to right squares, ovals, text boxes and callouts.
18	Flip over up and down squares, ovals, text boxes and callouts.
19	Rotate squares, ovals, text boxes and callouts clockwise.
20	Rotate squares, ovals, text boxes and callouts counterclockwise.
21	Properties of selected squares, ovals, text boxes and callouts.

Editing Title

Introduction A customized title can be added to a graph before printing.

Editing the title Follow the steps in the table below to add a title to the graph.

Step	Action
1	Have location plotted already.
2	Select the Edit Title button on the menu bar.
3	A Window will appear where you can edit the title for what you would like its name to be.
4	Select OK when the correct title is in the box. Result: The graph will be created with the new caption.



Figure 16. Edit Title Window.

Applying a Correction Factor

Introduction

A correction factor can be applied to the data collected with the EDC unit to account for variances in gravimetric readings.

Calculating a correction factor

The correction factor is calculated by dividing the Gravimetric reading by the EDC unit reading.

Applying a correction factor

Follow the steps in the table below to apply a correction factor to all data points in the current project folder.

Step	Action
1	Select the 2 nd Scale= with a box where you can type in your scale factor.
2	Type in the Scale factor.
3	After the scale factor is entered press enter. Result: All data points in the project folder have been multiplied by the correction factor.

Removing the correction factor

Follow the steps in the table below to remove the correction factor from the data points in the project folder.

Step	Action
1	Select the 1 st Scale= under the Dataset Scale Factor . Result: Data points should return to original state.

Inability to Download Data to PC

Introduction If DustComm Software installs properly but downloading instrument to computer is unsuccessful try the following:

- **Ensure that the RS232 cable connectors from the PC are *tightly screwed* into place.**
- **Ensure that the communications settings are set appropriately in the Download Properties screen of the DustComm program. Select Unit, Properties to access this dialog box. The communications port must be set to the appropriate Com Port used on the PC.**
- **If you are experiencing problems downloading your unit's results to your PC, and the RS232 cable connectors are secured tightly, your cable may be connected to the wrong 9-pin port on your PC. If your PC has more than one 9-pin connection port, attach the cable to another 9-pin port and try to download the dust monitor's results at that port. You may need to try all of your PC's 9-pin ports before finding the correct connection.**
- **If the previous steps check out, try using the Windows supplied HyperTerminal or other appropriately configured communications software to receive data when downloading from the Haz-Dust Monitor.**
- **If using a USB port, make sure you are using the proper USB to serial adapter.**

For service or Technical Questions please call 800-234-2589 or e-mail techsupport@hazdust.com

Chapter 5 - Maintenance

Chapter 5

Maintenance

Chapter Overview

Introduction This chapter covers the maintenance procedures for the Haz-Dust IV.

In this chapter This chapter contains the following topics.

Topic	See Page
Checking the Calibration Span.	5-2
Checking the Flow Rate.	5-5
Adjusting the Flow Rate.	5-7
Battery Maintenance.	5-8
Cleaning the Sensor Optics.	5-12

Checking the Calibration Span

Introduction The Calibration Reference is a light scattering device that provides a constant value (termed a “k” factor).

The Calibration Reference should be used as a reference to check factory calibration span of the Haz-Dust IV.

When to check the calibration span The calibration span should be checked under the following conditions:

- Once a month with normal usage.
- If the Haz-Dust IV is dropped or otherwise damaged.
- The first time you use the unit to double check the factory calibration.

Note: The Haz-Dust IV should be sent into EDC annually for recalibration.

Conditions The following conditions must be met before checking the calibration span.

Condition...	For further information see page...
The Sensor Optics must be clean.	5-11
The Environment must be clean.	---
The Battery must be fully charged.	5-7

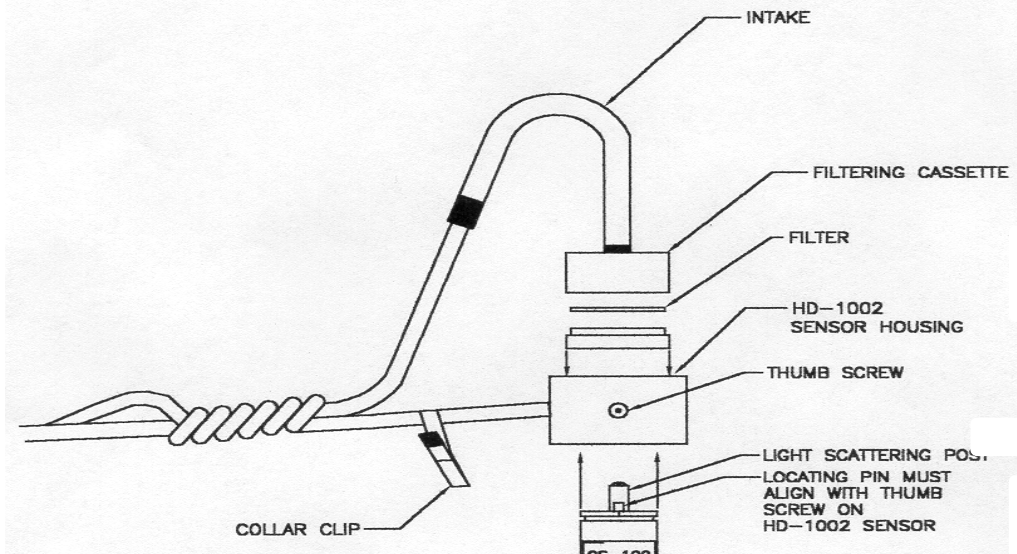

Figure 5-1. Diagram of the Haz-Dust IV showing the locating pin on the calibration reference.

Continued on next page

Checking the Calibration Span, Continued

Checking Calibration Span

Follow the steps in the table below to check the Calibration Span of the Haz-Dust IV.

Note: Failure to follow this procedure in its entirety may cause an incorrect “k” value reading.

Step	Action																		
1	Insert the Thoracic sampling inlet into the sensor head of the Haz-Dust IV.																		
2	Attach the filter cassette to the sensor of the Haz-Dust IV.																		
3	Attach the air intake hose to the filter cassette.																		
4	Put the Haz-Dust IV into Respirable mode using the steps below.																		
	<table border="1"> <thead> <tr> <th>Step</th> <th>Action</th> </tr> </thead> <tbody> <tr> <td>4-1</td> <td>Select Special Functions from the Main Menu.</td> </tr> <tr> <td>4-2</td> <td>Select System Options.</td> </tr> <tr> <td>4-3</td> <td>Select Extended Options.</td> </tr> <tr> <td>4-4</td> <td>Select Size Select.</td> </tr> <tr> <td>4-5</td> <td>Select Respirable.</td> </tr> <tr> <td colspan="2">Result: The Main Menu is displayed and the Haz-Dust IV is in Respirable mode.</td> </tr> </tbody> </table>	Step	Action	4-1	Select Special Functions from the Main Menu.	4-2	Select System Options .	4-3	Select Extended Options .	4-4	Select Size Select .	4-5	Select Respirable .	Result: The Main Menu is displayed and the Haz-Dust IV is in Respirable mode.					
Step	Action																		
4-1	Select Special Functions from the Main Menu.																		
4-2	Select System Options .																		
4-3	Select Extended Options .																		
4-4	Select Size Select .																		
4-5	Select Respirable .																		
Result: The Main Menu is displayed and the Haz-Dust IV is in Respirable mode.																			
5	Activate the internal pump using the steps in the table below.																		
	<table border="1"> <thead> <tr> <th>Step</th> <th>Action</th> </tr> </thead> <tbody> <tr> <td>5-1</td> <td>Select Sample/Record from the Main Menu.</td> </tr> <tr> <td>5-2</td> <td>Select 1 Second.</td> </tr> <tr> <td>5-3</td> <td>Select Overwrite.</td> </tr> <tr> <td>5-4</td> <td>Select Yes.</td> </tr> <tr> <td>5-5</td> <td>Select No.</td> </tr> <tr> <td>5-6</td> <td>Select Sample/Rec and allow the Haz-Dust IV to run for at least 2 minutes to stabilize.</td> </tr> <tr> <td colspan="2">Result: The internal sampling pump is activated.</td> </tr> <tr> <td>5-7</td> <td>Press ENTER after at least two minutes to stop the sampling process.</td> </tr> </tbody> </table>	Step	Action	5-1	Select Sample/Record from the Main Menu.	5-2	Select 1 Second .	5-3	Select Overwrite .	5-4	Select Yes .	5-5	Select No .	5-6	Select Sample/Rec and allow the Haz-Dust IV to run for at least 2 minutes to stabilize.	Result: The internal sampling pump is activated.		5-7	Press ENTER after at least two minutes to stop the sampling process.
Step	Action																		
5-1	Select Sample/Record from the Main Menu.																		
5-2	Select 1 Second .																		
5-3	Select Overwrite .																		
5-4	Select Yes .																		
5-5	Select No .																		
5-6	Select Sample/Rec and allow the Haz-Dust IV to run for at least 2 minutes to stabilize.																		
Result: The internal sampling pump is activated.																			
5-7	Press ENTER after at least two minutes to stop the sampling process.																		

Continued on next page

Checking the Calibration Span, Continued

6	Perform the Auto-Zero process using the steps in the table below.	
	Step	Action
	6-1	Insert the zeroing filter into the Thoracic sampling inlet.
	6-2	Select Special Functions from the Main Menu.
	6-3	Select System Options .
	6-4	Select Extended Options .
	6-5	Select Auto-Zero . Result: The Auto-Zeroing screen appears briefly.
	6-6	Select Auto-Zero . Results: <ul style="list-style-type: none"> • The Auto-Zeroing screen appears during the auto-zero process. • The Main Menu is displayed when the Auto-Zero process is complete.
7	Remove the Thoracic sampling inlet from the sensor head.	
8	Disconnect the air intake tubing.	
9	Insert the calibration reference into the sensor head (see diagram 5-1 on page 5-2). Note: Be sure the locating pin on the calibration reference slides into the locating hole on the sensor head.	
10	Activate the internal sampling pump again by repeating the process described in step number five on page 5-3. Skip step number 5-7 and leave the sampling pump running.	
11	Observe the printed “k” value on the calibration reference. Note: The printed “k” value should match the concentration value shown on the Haz-Dust IV LCD to within $\pm 10\%$. Note: If the CS-103 is purchased as an after market accessory or from SKC, Inc., then the user must assign a “k” value.	
	IF	THEN
	The numbers agree within $\pm 10\%$	The Haz-Dust IV has passed the span check test.
	The two numbers do not agree within $\pm 10\%$.	1. Repeat the process to rule out error, then 2. Call EDC technical support or return the Haz-Dust IV for recalibration.

Checking the Flow Rate

Introduction

It is good technique to check the flow rate every time a new gravimetric filter is used for sampling.

Checking the flow rate

Use the steps in the table below to check the flow rate.

Notes:

- If sampling Thoracic or Inhalable particulates make sure the Thoracic sampling inlet is attached to the sensor head.
- If sampling Respirable particulates make sure the Respirable sampling inlet is attached to the sensor head.

Step	Action	
1	Attach your airflow calibrator to the Haz-Dust IV using the table below.	
	If sampling...	Then...
	Thoracic or Inhalable Particulates	<ol style="list-style-type: none"> 1. Attach one end of the calibration airflow tubing to the Thoracic sampling inlet. 2. Connect the other end of the calibration airflow tubing to your airflow calibrator.
	Respirable Particulates	<ol style="list-style-type: none"> 1. Insert GS-Cyclone into cover of calibration chamber. Screw cover on tight. 2. Attach airflow calibrator to 90° nylon fitting. Attach Haz-Dust IV sensor to tygon tubing. See figure 5.2a. Consult calibration chamber instructions, p/n CH-103, for further detail.



Figure 5-2a. Haz-Dust IV sensor connected to CH-103 calibration chamber.

Continued on next page

Checking the Flow Rate, Continued

2	Activate the internal sampling pump using the steps below.															
	<table border="1"> <thead> <tr> <th data-bbox="565 352 711 390">Step</th> <th data-bbox="719 352 1386 390">Action</th> </tr> </thead> <tbody> <tr> <td data-bbox="565 390 711 428">1</td> <td data-bbox="719 390 1386 428">Select Sample/Record from the Main Menu</td> </tr> <tr> <td data-bbox="565 428 711 466">2</td> <td data-bbox="719 428 1386 466">Select 1 Second.</td> </tr> <tr> <td data-bbox="565 466 711 504">3</td> <td data-bbox="719 466 1386 504">Select Overwrite.</td> </tr> <tr> <td data-bbox="565 504 711 541">4</td> <td data-bbox="719 504 1386 541">Select Yes.</td> </tr> <tr> <td data-bbox="565 541 711 579">5</td> <td data-bbox="719 541 1386 579">Select No.</td> </tr> <tr> <td data-bbox="565 579 711 667">6</td> <td data-bbox="719 579 1386 667">Select Sample/Rec and allow the Haz-Dust IV to run for at least two minutes to stabilize.</td> </tr> </tbody> </table>		Step	Action	1	Select Sample/Record from the Main Menu	2	Select 1 Second.	3	Select Overwrite.	4	Select Yes.	5	Select No.	6	Select Sample/Rec and allow the Haz-Dust IV to run for at least two minutes to stabilize.
Step	Action															
1	Select Sample/Record from the Main Menu															
2	Select 1 Second.															
3	Select Overwrite.															
4	Select Yes.															
5	Select No.															
6	Select Sample/Rec and allow the Haz-Dust IV to run for at least two minutes to stabilize.															
3	Observe the flow rate on your air flow calibrator.															
	<table border="1"> <thead> <tr> <th data-bbox="565 783 938 821">If...</th> <th data-bbox="946 783 1386 821">Then...</th> </tr> </thead> <tbody> <tr> <td data-bbox="565 821 938 1010">The flow rate is 2.75 LPM.</td> <td data-bbox="946 821 1386 1010">The flow rate is properly calibrated. Detach the airflow calibrator tubing and continue with the “Selecting the Particle Size” process.</td> </tr> <tr> <td data-bbox="565 1010 938 1087">The flow rate is not 2.75 LPM.</td> <td data-bbox="946 1010 1386 1087">The flow rate must be adjusted. See page 5-7 for instructions.</td> </tr> </tbody> </table>		If...	Then...	The flow rate is 2.75 LPM.	The flow rate is properly calibrated. Detach the airflow calibrator tubing and continue with the “Selecting the Particle Size” process.	The flow rate is not 2.75 LPM.	The flow rate must be adjusted. See page 5-7 for instructions.								
If...	Then...															
The flow rate is 2.75 LPM.	The flow rate is properly calibrated. Detach the airflow calibrator tubing and continue with the “Selecting the Particle Size” process.															
The flow rate is not 2.75 LPM.	The flow rate must be adjusted. See page 5-7 for instructions.															
	<p>NOTE: The GS-3 Cyclone is an optional accessory for the Haz-Dust IV. Its optimal flow rate is 2.75 LPM. The GS-1 Cyclone may be used, however, its optimal flow rate of 2.0 LPM to a 4µm respirable cut point.</p>															
	<table border="1"> <tbody> <tr> <td data-bbox="565 1283 938 1451">Using the Thoracic inlet and the flow rate is 2.0 LPM.</td> <td data-bbox="946 1283 1386 1451">The flow rate is properly calibrated. Detach the airflow calibrator tubing and continue with the “Selecting the Particle Size” process.</td> </tr> <tr> <td data-bbox="565 1451 938 1539">The flow rate is not 2.0 LPM.</td> <td data-bbox="946 1451 1386 1539">The flow rate must be adjusted. See page 5-7 for instructions.</td> </tr> </tbody> </table>		Using the Thoracic inlet and the flow rate is 2.0 LPM.	The flow rate is properly calibrated. Detach the airflow calibrator tubing and continue with the “Selecting the Particle Size” process.	The flow rate is not 2.0 LPM.	The flow rate must be adjusted. See page 5-7 for instructions.										
Using the Thoracic inlet and the flow rate is 2.0 LPM.	The flow rate is properly calibrated. Detach the airflow calibrator tubing and continue with the “Selecting the Particle Size” process.															
The flow rate is not 2.0 LPM.	The flow rate must be adjusted. See page 5-7 for instructions.															
	<table border="1"> <tbody> <tr> <td data-bbox="565 1587 938 1766">Using the Inhalable inlet the flow rate is 2.0 LPM.</td> <td data-bbox="946 1587 1386 1766">The flow rate is properly calibrated. Detach the airflow calibrator tubing and continue with the “Selecting the Particle Size” process.</td> </tr> <tr> <td data-bbox="565 1766 938 1839">The Flow rate is not 2.0 LPM.</td> <td data-bbox="946 1766 1386 1839">The rate must be adjusted. See page 5-7 for instructions.</td> </tr> </tbody> </table>		Using the Inhalable inlet the flow rate is 2.0 LPM.	The flow rate is properly calibrated. Detach the airflow calibrator tubing and continue with the “Selecting the Particle Size” process.	The Flow rate is not 2.0 LPM.	The rate must be adjusted. See page 5-7 for instructions.										
Using the Inhalable inlet the flow rate is 2.0 LPM.	The flow rate is properly calibrated. Detach the airflow calibrator tubing and continue with the “Selecting the Particle Size” process.															
The Flow rate is not 2.0 LPM.	The rate must be adjusted. See page 5-7 for instructions.															

Adjusting the Flow Rate

Introduction

The flow rate must be adjusted when it does not equal:

- 2.75 LPM for 25-mm cyclone Respirable Inlet
 - 2.0 LPM for Thoracic Inlet
 - 2.0 LPM for Inhalable Inlet
-

Adjusting the flow rate

Follow the steps in the table below to adjust the flow rate.

1	Locate the adjustment screw on the bottom of the Haz-Dust IV next to the charging jack.						
2	Use the flow adjustment screw to adjust the flow rate.						
	<table border="1"><thead><tr><th>To...</th><th>Turn the adjustment screw...</th></tr></thead><tbody><tr><td>Decrease the flow rate</td><td>Counterclockwise</td></tr><tr><td>Increase the flow rate</td><td>Clockwise</td></tr></tbody></table>	To...	Turn the adjustment screw...	Decrease the flow rate	Counterclockwise	Increase the flow rate	Clockwise
To...	Turn the adjustment screw...						
Decrease the flow rate	Counterclockwise						
Increase the flow rate	Clockwise						
3	Record the Flow Rate.						
4	Detach the airflow calibrator and calibration airflow tubing.						
5	Continue with the “Selecting the Particle Size” process.						

Battery Maintenance

Introduction The battery pack is a 6.0 V NiMH rechargeable battery that can hold a charge for up to 8 hours. It is important to check the battery periodically and recharge when necessary.

Checking the Battery The battery status can be checked using the menu options on the Haz-Dust IV. Use the following menu options to check the battery.

Step	Action						
1	Select Special Functions from the Main Menu.						
2	Select Systems Options .						
3	Select Extended Options .						
4	Select Battery Status . Result: The Battery Level Screen displays the charging level of the unit's battery in VDC.						
5	<table border="1"><thead><tr><th>If the charge level is...</th><th>Then...</th></tr></thead><tbody><tr><td>6.2 VDC or higher</td><td>The battery is fully charged.</td></tr><tr><td>6.2 VDC or lower</td><td>The battery must be recharged. See instructions on page 5-9.</td></tr></tbody></table>	If the charge level is...	Then...	6.2 VDC or higher	The battery is fully charged.	6.2 VDC or lower	The battery must be recharged. See instructions on page 5-9.
If the charge level is...	Then...						
6.2 VDC or higher	The battery is fully charged.						
6.2 VDC or lower	The battery must be recharged. See instructions on page 5-9.						

Continued on next page

Battery Maintenance, Continued

Recharging the battery

Follow the steps in the table below to recharge the battery using the supplied charger.

Note: If the battery is low the sampling process will terminate and the low battery screen will display.

Step	Action
1	Plug the battery charger into an electrical outlet.
2	Plug the battery charger into the battery charge jack on the back of the battery plate. Results: <ul style="list-style-type: none">• The battery charge begins.• If the unit is off there will be no visible indication of the charge. Note: Recharging time is approximately 16 hours, and unit must be powered off when charging. If battery does not hold a charge for 8 hours, charge time can be increased to 24 hours. Typical lifetime of battery is 18 to 24 months. Batteries are warranty for 90 days upon receipt of shipment.

CAUTION: Do not charge in a hazardous environment. Use <i>only</i> the EDC approved charger designed for the Haz-Dust IV.
--

Continued on next page

Battery Maintenance, Continued

Removing and replacing the battery pack

The battery pack can be removed and replaced whenever necessary.

Note: The battery of the Haz-Dust IV can be recharged while either inside or outside of the instrument.

Removing the battery

Follow the steps in the table below to remove the battery pack.

Step	Action
1	Remove the two thumbscrews from the back plate of the Haz-Dust IV. Note: Screws are located under the waist belt.
2	Slide the battery plate out of the unit.
3	Unplug the nylon connector from its mating plug.
	Note: The battery pack is attached to the battery plate with a retaining bracket. The battery is not removable from the plate. Replacement batteries will come mounted on battery plates for easy replacement.

Continued on next page

Battery Maintenance, Continued

Reinstalling the battery Follow the steps in the table below to reinstall the battery pack.

Step	Action
2	Plug the nylon connector into its mating plug.
3	Slide the battery in the appropriate orientation into the battery cavity of the unit.
4	Insert the two thumbscrews to secure the battery pack in place.

Cleaning the Sensor Optics

Introduction

It is important to keep the sensor optics of the Haz-Dust IV clean to ensure the integrity of the optical sensor.

The sensor optics need to be checked every 48 hours when used in a 2 to 3 mg/m³ T.W.A. environment, and on a weekly or monthly basis in less contaminated locations.

Cleaning the Sensor Optics

Follow the steps in the table below to clean the sensor optics.



Figure 5-2. Picture of the cleaning kit.

Continued on next page

Cleaning the Sensor Optics, Continued

Step	Action
1	Remove the three thumbscrews from the sensor cover.
2	Remove the sensor cover.
3	Remove the sampling head from the bottom of the sensor.
4	Inspect the sensor cover for residual dust. Note: Use one of the following methods to clean the surface. <ul style="list-style-type: none">• Blow the dust away with low pressure air, or,• Wipe with a soft lint-free cloth.
5	Inspect the glass lens covers for dust. Note: Use one of the following methods to clean the glass lens. <ul style="list-style-type: none">• Blow the dust away with low pressure air, or,• Use a small amount of isopropyl alcohol and wipe with cotton swabs. CAUTION: Do not spill any alcohol into the internals of the Haz-Dust IV.
6	Replace the sampling head.
7	Replace the sensor cover.
8	Tighten the three thumbscrews snugly into place.

Continued on next page

Cleaning the Sensor Optics, Continued



Figure 5-3. Removing the sensor cover.



Figure 5-4. Dust being removed with low pressure air.



Figure 5-5. Isopropyl alcohol being applied to cotton swab.



Figure 5-6. Sensor head being cleaned with cotton swab.

Appendix

Appendix A

NIOSH/OSHA Particulate Air Monitoring Reference

Dust/Hazard	Agency	Reference	TWA	STEL
alpha-Alumina (Respirable fraction)	OSHA	CIM	5 mg/m ³	
alpha-Alumina (Total dust)	OSHA	CIM	15 mg/m ³	
Aluminum, Pyro powders	OSHA	CIM	*	
Aluminum (Respirable fraction)			5 mg/m ³	
Ammonium nitrate	OSHA	CIM	*	
Ammonium sulfamate (Respirable dust)	OSHA	CIM	5 mg/m ³	
Ammonium sulfamate (Total dust)	OSHA	CIM	15 mg/m ³	
Ammonium sulfamate (Total dust)	OSHA	ID 188	15 mg/m ³	
Bismuth telluride, Se-Doped	OSHA	ID 121	5 mg/m ³	
Bismuth telluride, Undoped (Respirable dust)	OSHA	ID 121	5 mg/m ³	
Bismuth telluride, Undoped (Total dust)	OSHA	CIM	15 mg/m ³	
Boron oxide (Total dust)	OSHA	ID 125G	15 mg/m ³	
Boron oxide (Total dust) (Particulates, Total)	NIOSH	0500	10 mg/m ³	
Carbon black	NIOSH	5000	3.5 mg/m ³	
Carbon black	OSHA	ID 196	3.5 mg/m ³	
Chromium, Metal & Insol cpds	OSHA	ID 121	1 mg/m ³	
Chromium, Metal & Insol cpds	OSHA	ID 125	1 mg/m ³	
Chrysene	OSHA	58	0.2 mg/m ³	
Coal dust (<than 5% SiO ₂)	OSHA	CIM	2.4 mg/m ³	
Coal dust (>than 5% SiO ₂)	OSHA	ID 142	10 mg/m ³	
Coal tar pitch volatiles	OSHA	58	0.2 mg/m ³	
Copper dust	NIOSH	7029	1 mg/m ³	
Copper, Dusts & Mists	OSHA	ID 125G	1 mg/m ³	
Copper, Dusts & Mists	OSHA	ID 121	1 mg/m ³	
Copper (Elements)	NIOSH	7300	1 mg/m ³	
Copper fume	NIOSH	7029	0.1 mg/m ³	
Copper fume	OSHA	ID 121	0.1 mg/m ³	
Copper fume	OSHA	ID 125G	0.1 mg/m ³	
Cotton dust (Raw)	OSHA	CIM	1 mg/m ³	

* Refer to Agency Method

Continued on next page

NIOSH/OSHA Particulate Air Monitoring Reference, Continued

Dust/Hazard	Agency	Reference	TWA	STEL
Crag herbicide (Respirable dust)	OSHA	CIM	5 mg/m ³	
Crag herbicide (Total dust)	NIOSH	5(S356)	10 mg/m ³	
Crag herbicide (Total dust)	OSHA	CIM	15 mg/m ³	
Cresol, All isomers	NIOSH	2546	10 mg/m ³	
Cresol, All isomers	OSHA	32	15 mg/m ³	
Cyanide (as Cn)	OSHA	ID 120	5 mg/m ³	
Fluorides (Aerosol & Gas)	NIOSH	7902	2.5 mg/m ³	5.0 (HF)
Glass, Fibrous dust	OSHA	CIM	*	
Glycerin mist (Particulates)	NIOSH	0600	*	
Glycerin mist (Respirable)	OSHA	CIM	5 mg/m ³	
Glycerin mist (Total dust)	OSHA	CIM	15 mg/m ³	
Grain dust (Oats, Wheat & Barely)	OSHA	CIM	10 mg/m ³	
Graphite, Synthetic (Respirable dust)	OSHA	CIM	5 mg/m ³	
Graphite, Synthetic (Total dust)	OSHA	CIM	15 mg/m ³	
Iodine (Particulates)	OSHA	ID 212	*	0.1
Kaolin (Respirable dust)	OSHA	CIM	5 mg/m ³	
Kaolin (Total dust)	OSHA	CIM	15 mg/m ³	
Lead	NIOSH	7082	<0.1 mg/m ³	
Lead	NIOSH	7105	<0.1 mg/m ³	
Lead	NIOSH	7700	<0.1 mg/m ³	
Lead (Elements)	NIOSH	7300	<0.1 mg/m ³	
Lead, Inorganic fumes & dusts (as Pb)	OSHA	ID 121	0.05 mg/m ³	
Lithium (Elements)	NIOSH	7300	*	
Lithium hydride	OSHA	CIM	25 µg/m ³	
Magnesium oxide fume (Total dust)	OSHA	ID 121	15 mg/m ³	
Manganese (Elements)	NIOSH	7300	1 mg/m ³	3 mg/m ³
Manganese fume (as Mn)	OSHA	ID 121	*	5 mg/m ³
Methoxychlor (Total Dust)	OSHA	CIM	15 mg/m ³	
Oil mist (Mineral)	OSHA	ID 128	5 mg/m ³	
Oil mist (Mineral)	OSHA	ID 178SG	5 mg/m ³	
Oil mist (Vegetable) (see Dust, Total and Respirable nuisance)				
Pentaerythritol (Total dust)	OSHA	CIM	15 mg/m ³	
Pentaerythritol (Respirable dust)	OSHA	CIM	5 mg/m ³	

Continued on next page

NIOSH/OSHA Particulate Air Monitoring Reference, Continued

Dust/Hazard	Agency	Reference	TWA	STEL
Picloram (Tordon), Respirable dust	OSHA	CIM	5 mg/m ³	
Picloram (Tordon), Total dust	OSHA	CIM	15 mg/m ³	
Plaster of Paris (see Dust, Respirable nuisance)	OSHA	CIM		
Portland cement (Respirable dust)	OSHA	ID 142	5 mg/m ³	
Portland cement (Total dust)	OSHA	ID 142	15 mg/m ³	
Respirable nuisance	OSHA	CIM	5.0 mg/m ³	
Respirable nuisance (Particulates)	NIOSH	0600	*	
Total nuisance	OSHA	CIM	15 mg/m ³	
Total nuisance (Particulates)	NIOSH	0500	10 mg/m ³	
Rouge (Respirable dust)	OSHA	CIM	5 mg/m ³	
Rouge (Total dust)	OSHA	CIM	15 mg/m ³	
Silica, Amorphous	OSHA	CIM	20 mppcf	
Silica, Crystalline tripoli, Respirable dust	OSHA	ID 142	0.05 mg/m ³	
Silicon carbide (Respirable dust)	OSHA	CIM	5 mg/m ³	
Silicon carbide (Total dust)	OSHA	CIM	15 mg/m ³	
Silicon (Respirable dust)	OSHA	CIM	5 mg/m ³	
Silicon (Total dust)	OSHA	CIM	15 mg/m ³	
Soapstone (Respirable dust)	OSHA	CIM	20 mppcf	
Soapstone (Total dust)	OSHA	CIM	6 mg/m ³	
Wood dust (except Western red cedar)	OSHA	CIM	*	
Wood dust (Western red cedar)	OSHA	CIM	2.5 mg/m ³	
Zinc bromide (see Dust, Total and Nuisance)			*	
Zinc oxide dust (see Dust, Total & Respirable)	OSHA	CIM		
Zinc oxide fume	OSHA	ID 121	5 mg/m ³	
Zinc oxide fume	OSHA	ID 125	5 mg/m ³	
Zinc oxide fume	OSHA	ID 143	5 mg/m ³	
Zinc stearate (Respirable dust)	OSHA	CIM	5 mg/m ³	
Zinc stearate (Total dust)	OSHA	ID 121	15 mg/m ³	
Zinc stearate (Total dust)	OSHA	ID 125	15 mg/m ³	
Zirconium cpds (as Zr)	OSHA	ID 121	5 mg/m ³	

Appendix B

Particle Size Selections

Introduction The tables below show the particle size cut point for Thoracic, Inhalable, and Respirable dust particles.

Inhalable	
Particle Aerodynamic Diameter (μm)	Inhalable Particulate Mass (IPM) (%)
0	100
1	97
2	94
5	87
10	77
20	65
30	58
40	54.5
50	52.5
100	50

Respirable	
Particle Aerodynamic Diameter (μm)	Respirable Particulate Mass (RPM) (%)
0	100
1	97
2	91
3	74
4	50
5	30
6	17
7	9
8	5
10	1

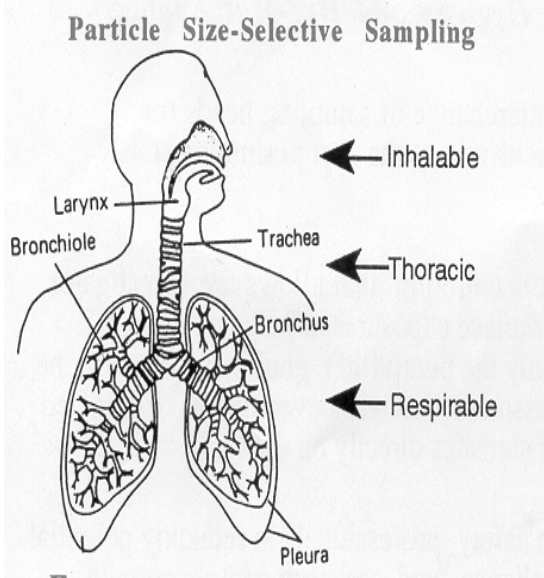

Thoracic	
Particle Aerodynamic Diameter (μm)	Thoracic Particulate Mass (TPM) (%)
0	100
2	94
4	89
6	80.5
8	67
10	50*
12	35
14	23
16	15
18	9.5
20	6
25	2

* Same cut point as EPA PM-10.

Appendix C

Glossary of Terms

Term	Definition/Standard
µm	Micron, 1/1000 of a meter.
ARD	Arizona Road Dust
Inhalable Dust Particulates	Particulates having a 50% cut point at 100µm.
LPM	Liters per minute.
mg/m ³	Milligrams per cubic meter.
NIOSH	National Institute of Occupational Safety & Health
OSHA	Occupational Safety & Health Administration.
Respirable Dust Particulates	Particulates having a 50% cut point at 3.5µm.
STEL	Short-term exposure level. Maximum dust concentration over a 15 minute period.
Thoracic Particulates	Particulates having a 50% cut point at 10µm.
TWA	Time Weighted Average. Average particulate concentration over a period of time.

Appendix D

Haz-Dust IV Accessories

Overview

Introduction Accessories may be purchased separately for the Haz-Dust IV.

Accessory and part number Use the part number from the table below to order Haz-Dust IV accessories.

Accessory	Part Number
110 V	BC-104-110
220 V	BC-104-220
37 mm Opaque Filter Cassette Blanks	CAS-103
5.0 µm PVC 37 mm Filter	225-806
Battery Pack	BP-104
Calibration Reference	CS-103
Calibration Chamber	CH-103
Cleaning Kit	KK-101
Computer Interface Cable	CC-102
Durable Carrying Case	DCC-104
Flow Meter	FM-103
HD-1003 Media CD-Rom Includes: Computer Software and Instructions Manual	CD-104
IOM Sensor Inlet	IS-104
Respirable Dust Cyclone Inlet	RS-103
Thoracic Sample Inlet	TS-103
Tripod Stand	TP-104
Zeroing Filter	ZF-102
