

G

GAS PROPORTIONERS BACK PRESSURE COMPENSATED

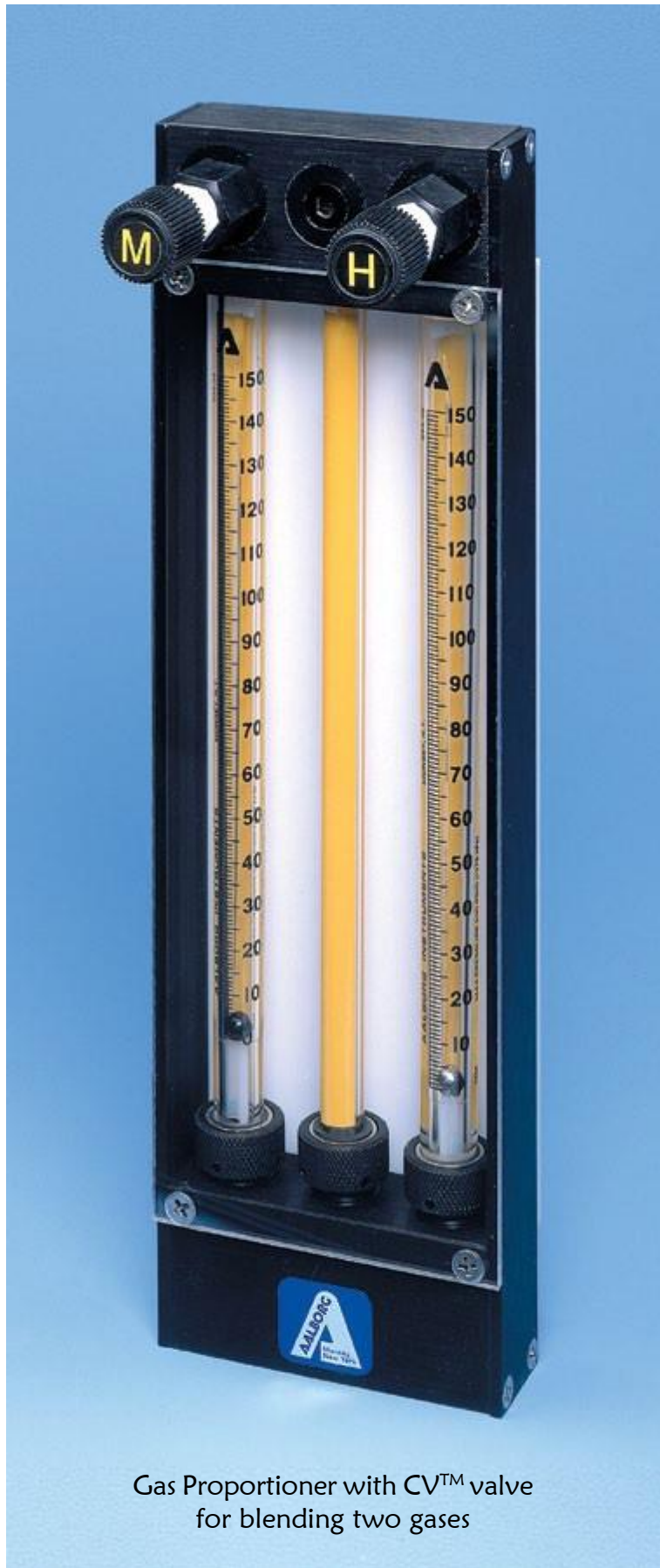

Gas Proportioner with CV™ valve
for blending two gases

To blend two or three gases in homogeneous infinitely variable concentrations, directly at the end use point, this Model G gas proportioner is unsurpassed in convenience and economy.

Gas proportioners pay for themselves since they eliminate the need for expensive custom blended gas mixtures.

They lend flexibility and economy to the utilization of component gas cylinders and "piped-in" supply lines.

**Another advantage
in laboratory investigations is
the freedom to reproducibility
increase or decrease
concentrations during
the course of an experiment.**

The flow rates are not affected by downstream pressure variations as long as back pressures do not approach or exceed the input pressure. Input pressures of up to 200 psig (13.8 bars) can be used; however, customers' very often find 50 psig (3.45 bars) a convenient setting to work with.

design features

- ✓ Blending of two or three gases with gas proportioners obviates the need for:
 - ✓ ordering fixed gas mixtures.
 - ✓ contamination from reusable gas cylinders.
 - ✓ potentially inaccurate mixtures by gas suppliers.
- ✓ Rib-guided or fluted metering tubes facilitate stable, accurate readings.
- ✓ OPTIGRAD™ scales minimize parallax and eye fatigue.
- ✓ Interchangeability of flow tubes and floats.
- ✓ Simple means of panel mounting.

BUILT-IN VALVES

Meters are available with built-in needle valves (CV™), high precision metering valves (MFV™) with “non-rising stems”, or with no valves.

The higher cost of MFV™ valves is justified whenever high sensitivity control and resolution are desirable particularly in conjunction with metering tubes of very low flow rates.

design features

- ✓ Precision fabricated from heavy walled, shock resistant borosilicate glass.
- ✓ Bores are uniformly tapered or formed with internal “rib-guides” or flutes.
- ✓ Floats are retained by TFE plugs.
- ✓ Self cleaning.
- ✓ Low differential pressures that stay independent of flow rate changes.

DIMENSIONS FOR G STYLE METERS

WIDTH (W)		
SCALE LENGTH	2 CHANNEL	3 CHANNEL
150 mm	3.24	4.23

Bench mounting acrylic tripod bases are optional.

DIMENSIONS

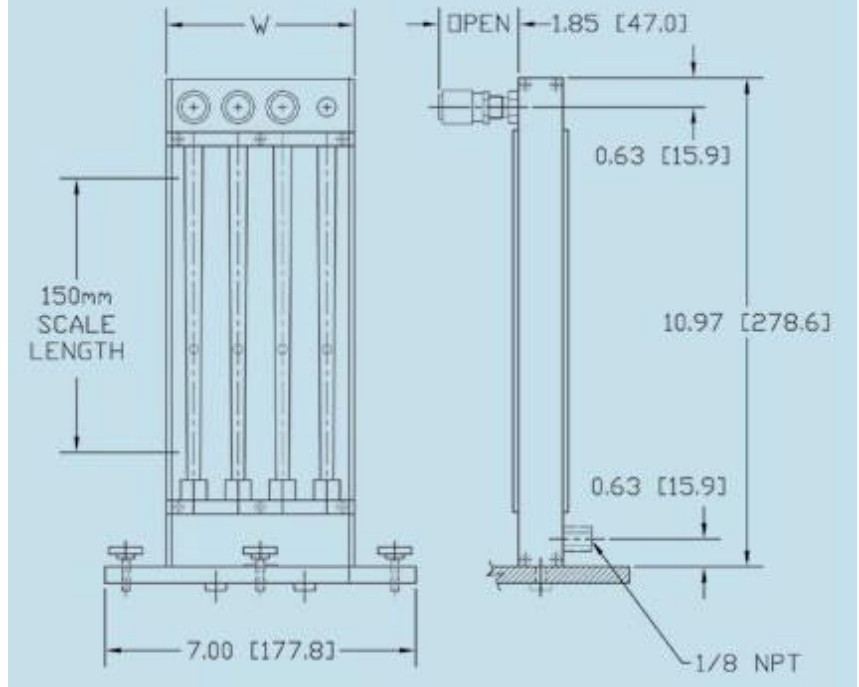

SPECIFICATIONS STANDARD COMPONENT

FLOW TUBE ACCURACY

±2% FS mm scales except 042 and 032 flow tubes ±5%, from 10 to 100% of scale. Conforming to ISA RP. 16-1.2.3. Specification 2-S-10.

COMPONENT FLOW TUBE REPEATABILITY

±0.25%. Typical calibration curves for air at 50 psig /3.5 bars using glass floats are available. Consult the company on the availability of calibration data for non-hazardous gases and special individual calibrations.

MAX OPERATING PRESSURE 200 psig/13.8 bars.

MAX OPERATING TEMPERATURE 250 °F/ 121 °C.

**MATERIALS OF CONSTRUCTION

FLOW TUBES Heavy walled borosilicate glass.

CHOICE OF MOUNTING FITTINGS IN CONTACT WITH GASES

a) Aluminum, black anodized. b) 316 stainless steel.

SIDE PANELS Aluminum, black anodized.

FRONT SHIELD Clear polycarbonate.

BACK PLATE 1/8" thick white acrylics.

O-RINGS AND PACKING Buna® O-rings in aluminum model.

FKM, O-rings in stainless steel meters.

OPTIONAL FKM, PTFE/FFKM/EPR.

CONNECTIONS 1/8" NPT female inlet and outlet connections.

OPTIONAL Hose and compression fittings are available.

**The selection of materials of construction, is the responsibility of the customer. The company accepts no liability.